



LECOSYS[®]

ISOTTA

DESIGN LORENZO MARCOLIN

Isotta management tables
Isotta meeting tables
Isottina work stations
Isi wall storage units
Isi screen integrated systems
Isi utility box
Isi speak lectern

Isotta tables/direction
Isotta meeting tables/réunion
Isottina postes de travail
Isi wall parois équipées
Isi screen panneaux intégrés
Isi box utility caissons à tiroirs
Isi speak pupitre

Isotta Direktionstische
Isotta meeting Besprechungstische
Isottina Arbeitsposten
Isi wall Wände mit Stauraum
Isi screen integrierte Leisten
Isi Utility Box
Isi speak Lesepult

isotta

Isotta tavoli direzionali
Isotta meeting tavoli riunione
Isottina postazioni di lavoro
Isi wall pareti contenitore
Isi screen schermi integrati
Isi box utility
Isi speak leggii

DESIGN LORENZO MARCOLIN

Isotta è un programma di arredi che, con tensioni estetiche dinamiche e positive, organizza lo spazio ufficio in luoghi di qualità tipologica e funzionale: dalla scrivania dirigenziale alle aree di riunione alle postazioni operative.

Isotta is a range of furniture that, with a dynamic and positive design, organises the office space into different types of function: from the managerial desk to the meeting areas and the operator positions.

Isotta consiste en un programme de meubles qui organisent votre espace bureau, pour le transformer en habitat de qualité au point de vue typologique et fonctionnel, grâce à leurs tendances esthétiques, dynamiques et positives: de la table/direction aux espaces réunion, en passant par les postes de travail modulaires.

Isotta ist ein Einrichtungsprogramm zur ästhetischen, dynamischen und positiv spannungsgeladenen Gestaltung von Büroräumen, bei der typologische und funktionelle Qualität den Ton angeben: vom Managementschreibtisch zu den einzelnen Arbeitsplätzen über Sitzungsmodule.





Una struttura forte e solidale costituita da telai in tubolare di acciaio diversamente articolati, per mezzo di giunti in pressofusione di alluminio sostiene piani di lavoro qualsiasi. Una piccola idea di grande valore espressivo e comunicativo.

A strong and solid structure constructed from tubular steel frames variously articulated, through die-cast aluminium joints, supports any work top. A small idea with great expression and communication value.

Une structure forte et solidaire: elle comprend des plâtements en acier tubulaire articulés de différentes façons par des joints en moulage d'aluminium sous pression, qui sont en mesure de supporter n'importe quel plateau. Une petite idée, pour une grande valeur expressive et communicative.

Eine robuste solide Struktur in Form von unterschiedlich zusammengesetzten Unterbauten aus Stahlrohren und Aluminiumpressgussteilen trägt Arbeitsflächen aller Art. Eine kleine Idee vom großen expressiven und kommunikativen Wert.





Shaped work tops laid out in constantly changing office spaces. Places where, by taking into account our emotions and feelings, we can look forward to the future with competence and professionalism.

Des plateaux profilés dans des espaces bureaux évolutifs, des habitats où les émotions et les sentiments ne sont pas dédaignés, par conséquent vous pouvez leur confier le futur de la compétence et du professionnalisme.

Arbeitsflächen mit Formgebung für Büroräume in kontinuierlicher Entwicklung. Räume, in denen die Zukunft Fachwissen und Professionalität anvertraut ist, aber auch Emotionen ihren Platz haben.

Piani di lavoro sagomati collocati in spazi ufficio in continua evoluzione, ambiti in cui non fuggendo le emozioni ed i sentimenti, affidare alla competenza e alla professionalità il futuro.

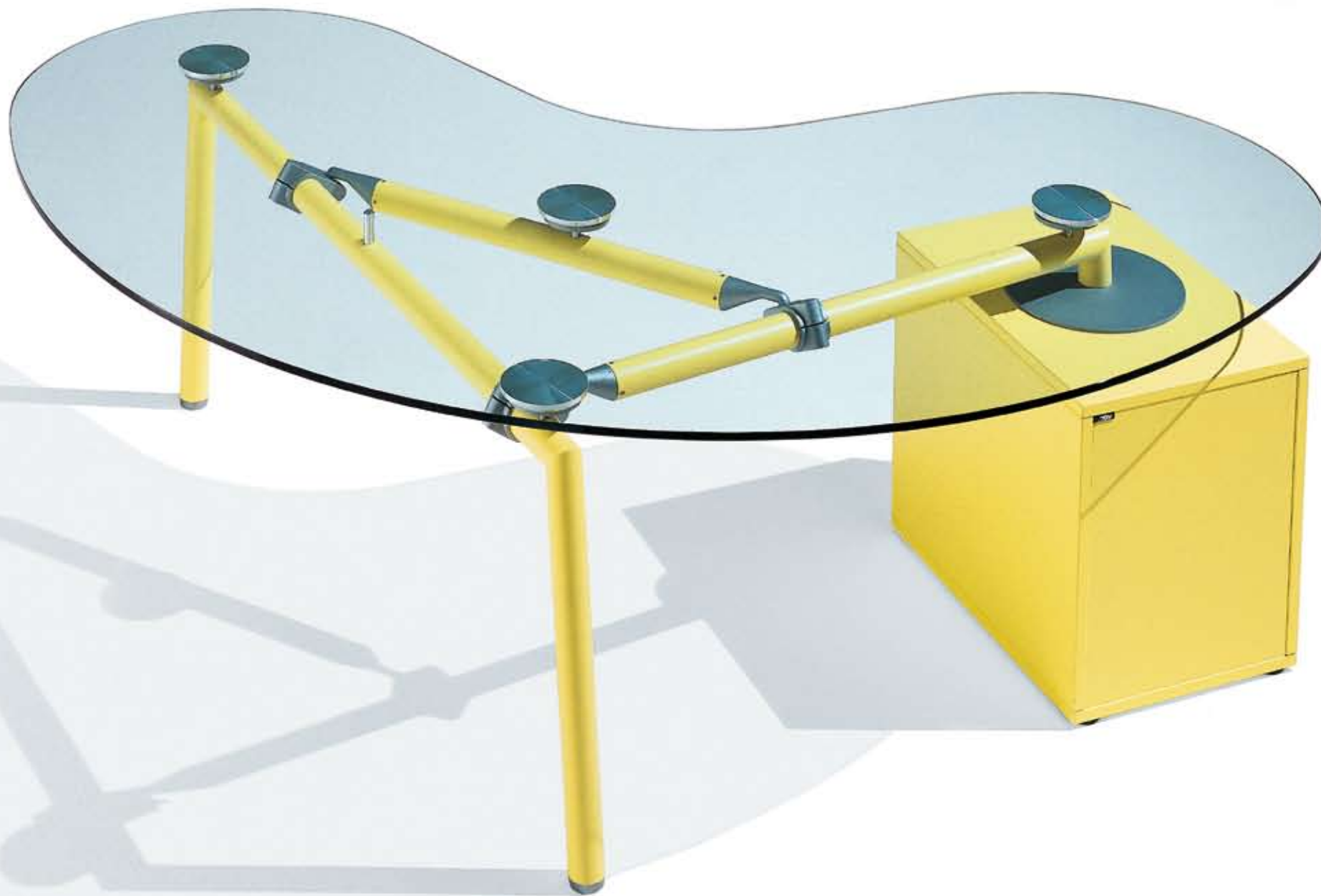

MISOTA
6 7

Ambienti colorati, distinguibili e personalizzabili in cui lavorare innovativamente.

Coloured environments, which can be distinguished and personalised, to work in, with new ideas.

Des habitats colorés, caractéristiques et personnalisés, où vous pouvez travailler d'une manière innovante.

Farbe und individuelle Ausführung für Räume, wo innovativ gearbeitet wird.





Styled tops for organising work with simple but professional elegance, where meeting, interfacing and dealing are simple actions.

Des plateaux profilés pour organiser vos activités avec une élégance simple et professionnelle, dans un habitat où vous pourrez facilement vous connecter, vous interfacer et vous rapporter aux autres.

Formgestaltete Flächen, um alle Aufgaben mit einfacher, jedoch professioneller Eleganz organisieren und schnell kommunizieren bzw. interagieren zu können.

Piani sagomati per organizzare le attività con semplice ma professionale eleganza dove connettersi, interfacciarsi, relazionarsi sono facili azioni.

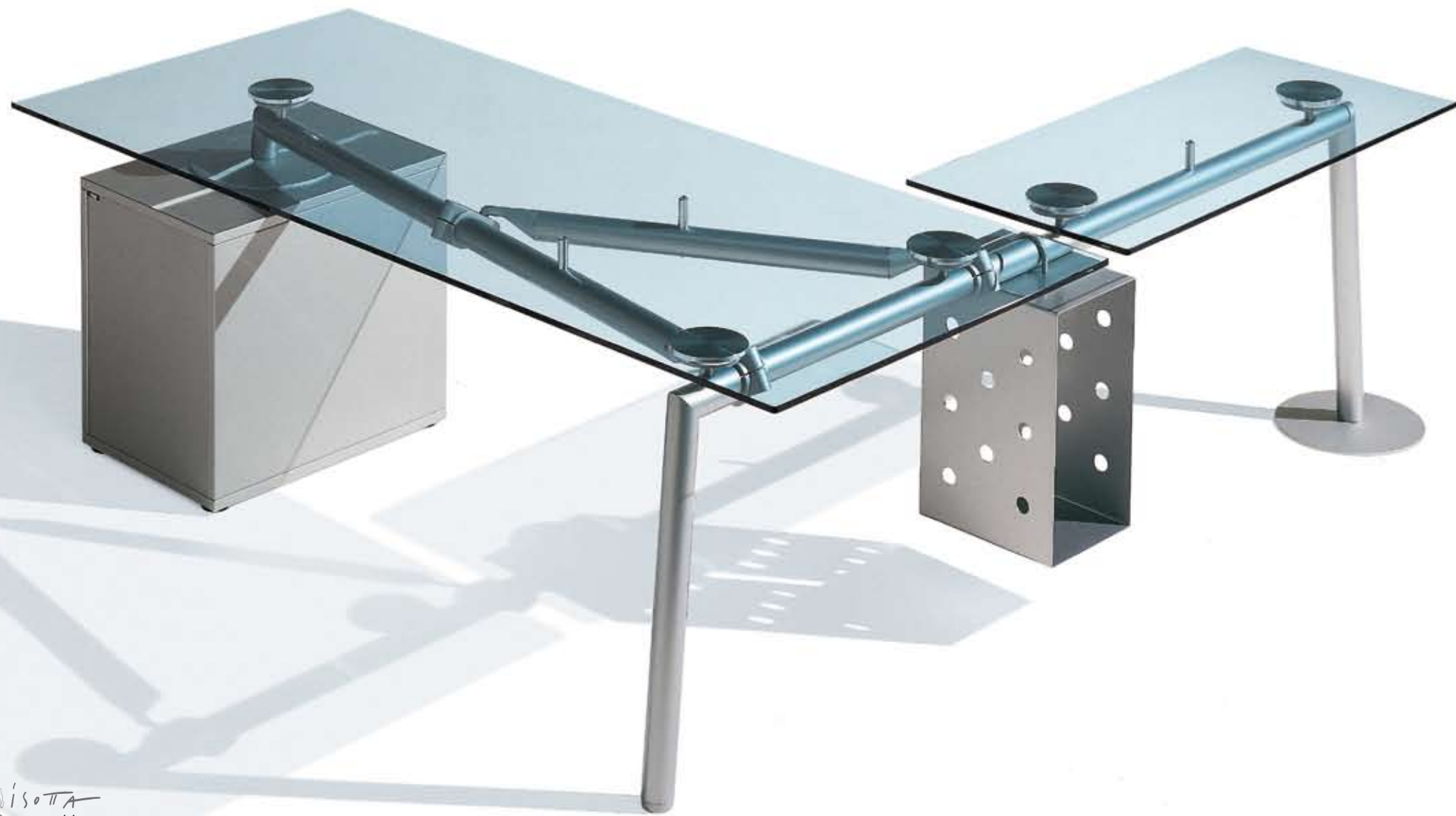

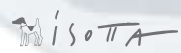

 10 11

Strutture in acciaio collegate da giunti pressofusi, piani in vetro trasparente o sabbciato, cassettiere ed elementi di servizio supportano con la medesima efficacia, attività pratiche e relazionali.

Steel structures connected by die-cast joints, transparent or sandblasted glass tops, drawer units and service elements support, with the same efficacy, practical activity and relationships.

Des structures en acier articulées par des joints moulés sous pression, des plateaux en verre transparent ou transuicié, des éléments de rangement et des éléments de service pour secondar avec la même efficacité des activités pratiques et relationnelles.

Stahlstrukturen, die mit Druckgussteilen verbunden sind, Transparent- oder Mattglasflächen, Schubladen- und Ablageelemente unterstützen wirkungsvoll praktische bzw. Schreibfähigkeiten.





MISOTA
12 13

Luoghi di lavoro collegati all'attualità e proiettati alla globalità in cui l'essere versatili, adattabili e trasformabili sono le caratteristiche vincenti.

Work places suited to the new millennium, designed for the whole, where versatility, adaptability and transformability are the winning features.

Des lieux de travail en relation avec l'actualité et projetés vers la mondialisation où, les caractéristiques gagnantes sont l'universalité, l'adaptabilité et la transformabilité.

Arbeitsplätze, die mit Realität und Globalität in Verbindung stehen, in der man wendig, anpassungsfähig und wandlungsbereit sein muss.



Confrontarsi, relazionarsi sono le opportunità che caratterizzano gli spazi di riunione in cui **Isotta meeting** interviene elegantemente. Leggii **Isi speak** e pareti contenitore **Isi wall** completano e definiscono l'ambito di appartenenza e di trasformazione.

Meeting and reporting are the opportunities that characterise the meeting areas for which **Isotta meeting** has been designed. **Isi speak** lecterns and **Isi wall** storage walls complete and define the atmosphere of belonging and of transformation.

Supporter la confrontation, se rapporter aux autres, ce sont les possibilités qui caractérisent les espaces réunion ou **Isotta meeting** intervient élégamment. Les pupitres **Isi speak** et les parois équipées **Isi wall** complètent et définissent le cadre d'appartenance et de transformation.

Auseinandersetzung und Kommunikation bestimmen die Versammlungsräume, in denen **Isotta meeting** eingreift. **Isi speak** Lesepulte und **Isi wall** Wände mit Stauraum ergänzen und definieren einen Kontext der Zugehörigkeit und Wandelbarkeit.



MISOTA
16 17

La trasparenza dei piani in vetro sostenuti da solide strutture metalliche sono il supporto per importanti rapporti relazionali.

The clearness of the glass surfaces, supported by solid metal structures, are the support for relationships.

La transparence des plateaux en verre qui reposent sur des structures métalliques solides est le support de relations interpersonnelles importantes.

Die Transparenz der Glasplatten auf soliden Metallstrukturen trägt zu wichtigen Beziehungen bei.



Linearità geometrica ed interazione cromatica sono gli aspetti formali caratteristici del sistema **Isi wall**. Esso è l'intorno funzionale alle postazioni di lavoro **Isotta** e consiste in pannelli-parete contenitori, utilizzabili singolarmente o in serie, ottenuti mediante la semplice sovrapposizione di elementi con apertura a ribalta. La possibilità di disporre di ante di diversi colori e finiture permette la composizione di spazialità nuove e vitali, costantemente trasformabili e personalizzabili.

Geometrical lines and chromatic interaction are the design characteristics of the **Isi wall** system. It forms the functional surrounding for **Isotta** work pieces, consisting of panels-wall storage units, which can be used individually or in series. This is done by simply stacking the elements on top of each other, which have a front tilting door. The option of using doors of different colours and finishes allows new and exciting spaces to be designed, which can be constantly transformed and personalised to meet changing requirements.

La linéarité géométrique et l'interaction chromatique sont les aspects formels et caractéristiques du système **Isi wall** qui constitue le cœur fonctionnel des postes de travail **Isotta**. Cet ensemble comprend des panneaux-cloisons que vous pouvez utiliser un par un ou en série, en superposant simplement les éléments qui s'ouvrent par abattant. Les portes sont disponibles dans des couleurs et des finitions différentes, ce qui vous permet de composer de nouveaux espaces vitaux, que vous pourrez transformer et personnaliser à tout moment.

Geometrische Linearität und farbliche Interaktion sind die formellen Aspekte des Systems **Isi wall**. Es bildet den funktionellen Rahmen der **Isotta** Arbeitsplätze und besteht aus Wandpaneelen mit Stauraum, die einzeln oder aneinandergereiht zu verwenden sind und durch das einfache Übereinandersetzen von Elementen mit Kipptüren entstehen. Durch den Einsatz von Türen mit unterschiedlicher Farb- und Oberflächengestaltung kann der Raum neu und vital, stets wandelbar und individuell organisiert werden.







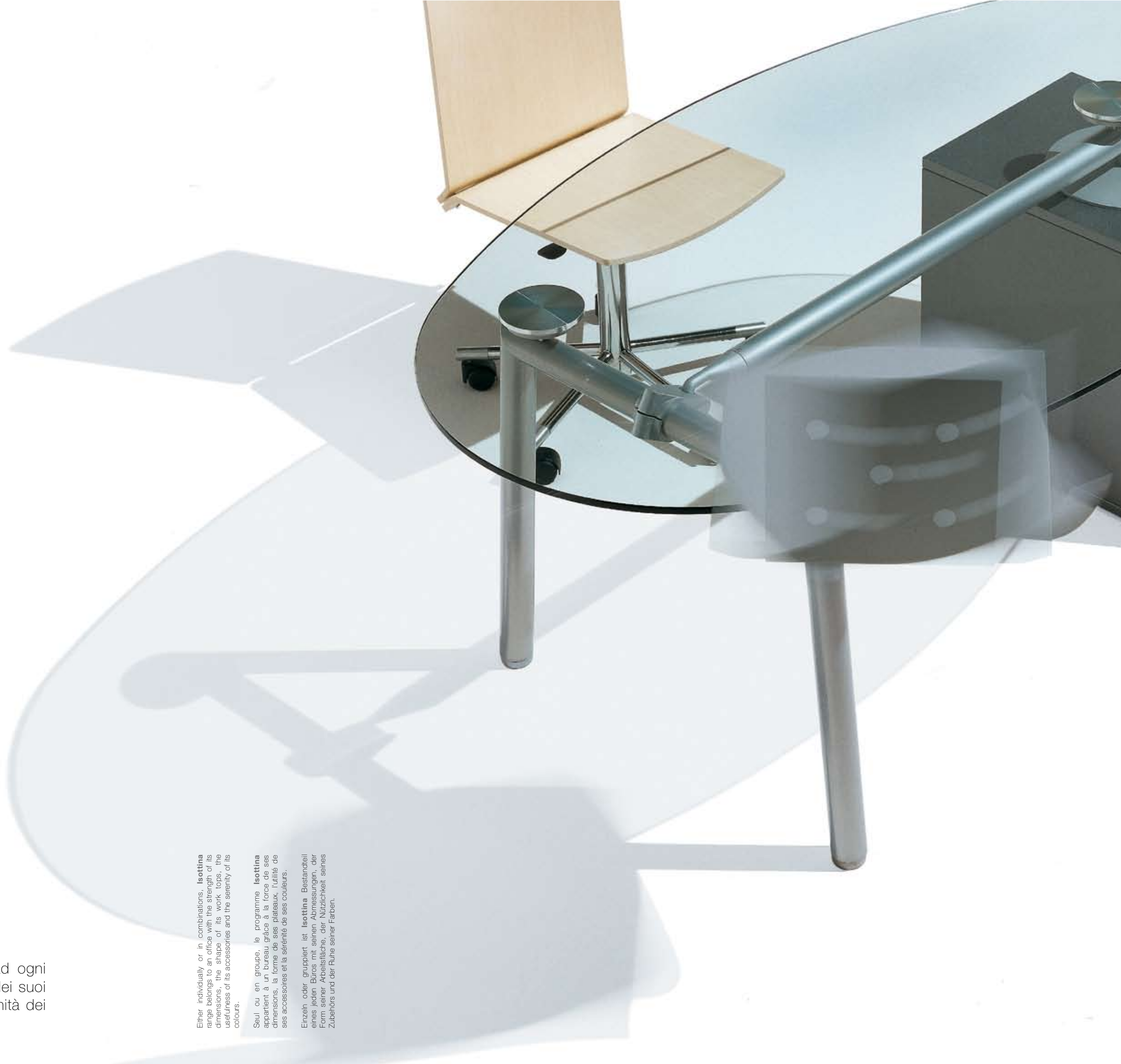

Singolarmente o in gruppo **Isottina** appartiene ad ogni ufficio con la forza delle sue dimensioni, la forma dei suoi piani di lavoro, l'utilità dei suoi accessori e la serenità dei suoi colori.

Either individually or in combinations, **Isottina** ranges belongs to an office with the strength of its dimensions, the shape of its work tops, the usefulness of its accessories and the serenity of its colours.

Seul ou en groupe, le programme **Isottina** appartient à un bureau grâce à la force de ses dimensions, la forme de ses plateaux, l'utilité de ses accessoires et la sérénité de ses couleurs.

Einzel oder gruppiert ist **Isottina** Bestandteil eines jeden Büros mit seinen Abmessungen, der Form seiner Arbeitsfläche, der Nützlichkeit seines Zubehörs und der Ruhe seiner Farben.



Box utility, fixed or mobile, can become operating work surfaces, which can be freely organised and easily laid out in state-of-the-art office spaces.

Qu'ils soient fixes ou mobiles, les caissons à trois **box utility** positionnent les tables de travail que vous pourrez organiser facilement en toute liberté dans les espaces bureaux contemporains.

Fest montierte oder mobile **utility boxen** zum Positionieren von Arbeitsflächen im Sinne freier Organisation und einfacher Anordnung in modernen Büroräumen.

Box utility fissi o mobili posizionano piani operativi liberamente organizzabili e facilmente collocabili negli spazi ufficio contemporanei.



MISOTA
28 29

Girevoli di servizio, diversamente sagomati permettono di liberare il piano di lavoro e di ordinarlo in ambiti di utilizzo diversi: sostenere una tazza di thé, consultare un testo, posizionare il video alla giusta distanza....

Rotary service units, with various designs, allow the work top to be freed up, and to be installed in various different places: to hold a cup of tea, consult a book, or position the video at the right distance...

Les plateaux de service tournants aux formes diverses permettent de libérer le plateau et de l'agencer dans des contextes d'utilisation différents: support d'une tasse de thé, consultation d'un texte, positionnement de l'écran vidéo à une distance correcte ...

Drehgestelle mit unterschiedlicher Formgebung für eine freie und geordnete Arbeitsfläche. Der Verwendungszweck ist vielfach: eine Teetasse abstellen, ein aufgeschlagenes Buch bereithalten, den Bildschirm richtig positionieren ...





The extendable separating of the service top allows the **box utility** to be fully made use of, both as a storage and as a lateral work unit.

Le plateau de service allongeable permet d'utiliser entièrement le caisson à trois **box utility**, aussi bien comme élément de rangement que comme poste de travail latéral.

Die ausziehbare Trennmöglichkeit der Abstellfläche gestattet die Verwendung der **utility box** sowohl als Behälter als auch als seitlichen Arbeitsplatz.

La separabilità estendibile del piano di servizio permette il completo utilizzo del **box utility**, sia come contenitore che come postazione laterale di lavoro.



Schermi elettrici integrati **Isi screen** affiancati ai piani di lavoro, posizionando le prese elettriche e telefoniche e sostenendo mensole di servizio realizzano ottimali e autonomi ambiti di operatività.

Isi screen integrated electrical screens alongside the work surfaces, by positioning the electric supply sockets and telephone points and supporting service shelves, create optimum and autonomous operational workplaces.

Les panneaux électriques intégrés **Isi screen** sont associés aux plateaux pour contenir les prises électriques, téléphoniques, et supporter des étagères de service. Le tout vous permet de réaliser des postes de travail optimaux et indépendants.

Integrierte **Isi screen** Leisten, die den Arbeitsflächen Steckdosen und Telefonanschluss-buchsen sowie Tragekonsolen zuordnen, schaffen optimale und autonome Arbeitsumfelder.



Workplaces for thinking, designing, programming
and working positively in every space, either alone
or together.

Des lieux de travail pour penser, concevoir,
programmer, opérer d'une manière positive dans
chaque espace, seule(e) ou avec les autres.

Arbeitsplätze zum positiven Denken, Entwerfen,
Planen und Agieren allein oder zusammen mit
anderen.

Luoghi di lavoro per pensare, progettare, programmare,
operare positivamente in ogni spazio da soli o insieme agli
altri.

Isi wall

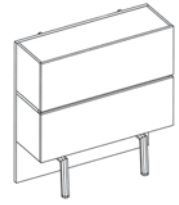

IWALL118 H 118 L 110 P 43

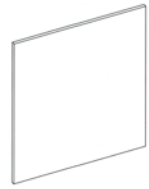

IWALL118P H 118 L 110 P 3



IWALL118E H 118 L 110 P 78



IWALL118M H 118 L 110 P 40



IWALL118D H 118 L 110 P 82

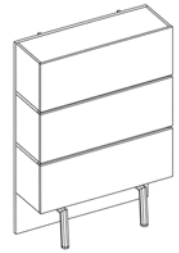

IWALL160 H 160 L 110 P 43



IWALL160P H 160 L 110 P 3



IWALL160E H 160 L 110 P 78

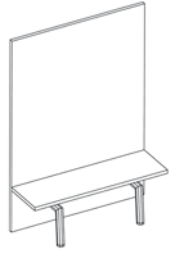

IWALL160M H 160 L 110 P 40



IWALL160D H 160 L 110 P 82

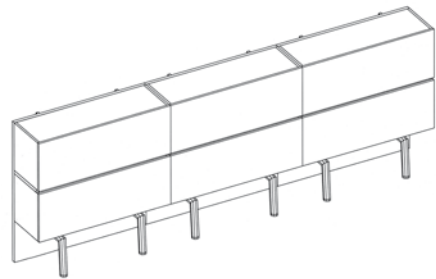

IWALL1183 H 118 L 330 P 43

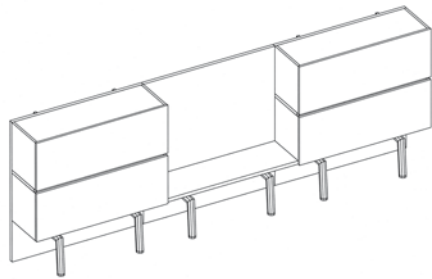

IWALL1183M H 118 L 330 P 43

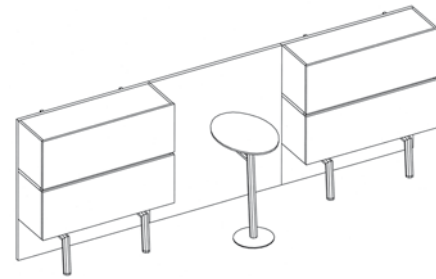

IWALL1183E H 118 L 330 P 82

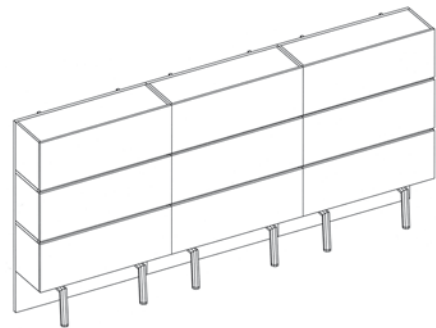

IWALL1603 H 160 L 330 P 43

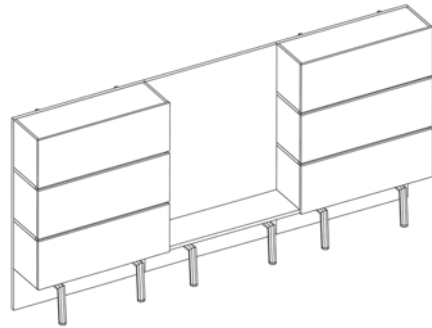

IWALL1603M H 160 L 330 P 43

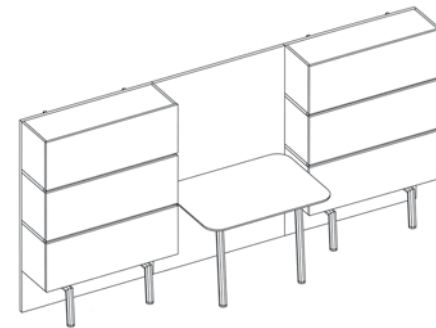

IWALL1603D H 160 L 330 P 86

Isotta

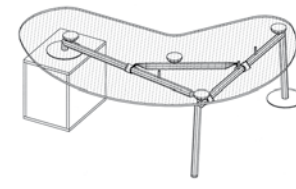

ISO 703 H 74 L 224 P 198

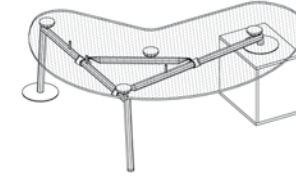

ISO 704 H 74 L 224 P 198

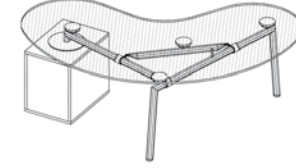

ISO 303 H 74 L 200 P 183

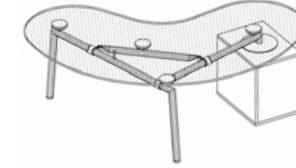

ISO 304 H 74 L 200 P 183

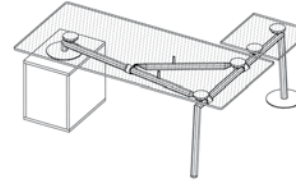

ISO 161 H 74 L 200 P 170

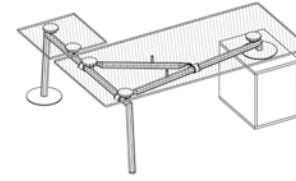

ISO 162 H 74 L 200 P 170

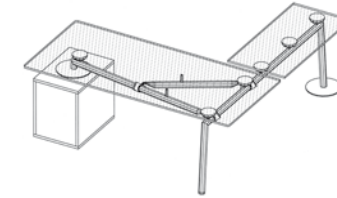

ISO 171 H 74 L 200 P 220

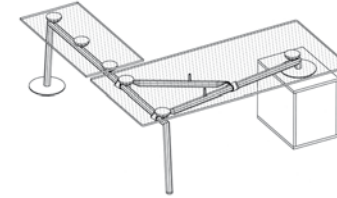

ISO 172 H 74 L 200 P 220



ISO 64E H 88 L 45 P 88



ISO 40 H 82 L 40 P 88

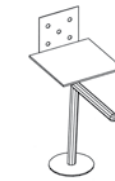

ISO 45C H 88/115 L 45 P 88



ISO 908 H 45 L 21 P 30

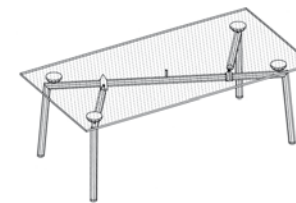

INA 210 H 74 L 210 P 105

Isotta meeting



ISO 900 H 74 Ø 130

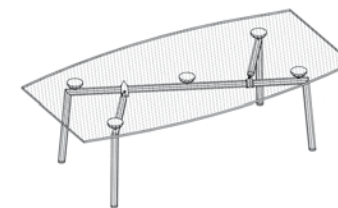

ISO 909 H 74 L 250 P 100/130

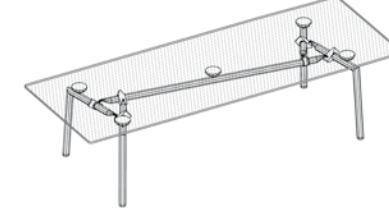

ISO 911 H 74 L 300 P 110

Isi speak



ISISP H 126 L 64 P 49

isotta

isotta

Isottina

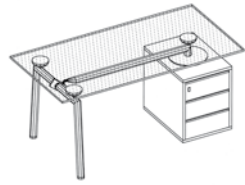

INA 160 H 73 L 160 P 82

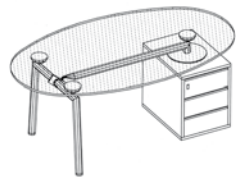

INA 184 H 73 L 184 P 106

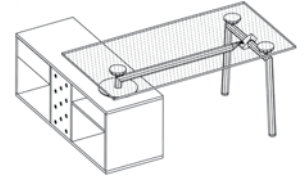

INA 160L H 73 L 160 P 151

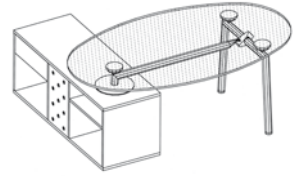

INA 184L H 73 L 184 P 164

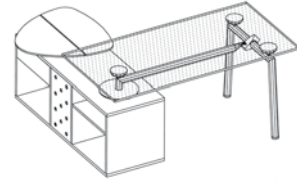

INA160LC H 73 L 172 P 161

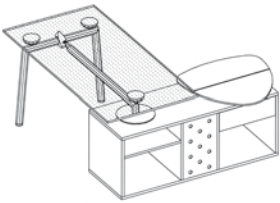

INA161LC H 73 L 172 P 161



INA64 H 3/30 L 45 P 64



INA40 H 3 Ø 40



INA45 H 3/30 L 45 P 45



ISO 908 H 45 L 21 P 30

Isi

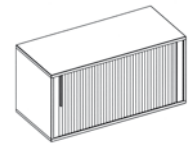

ISH110 H 55 L 110 P 50

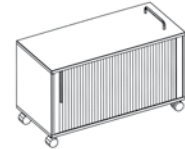

ISH110R H 65/72 L 110 P 50

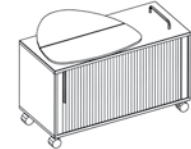

ISH110CR H 81 L 110 P 70

Isi screen

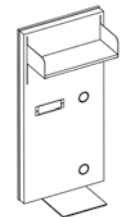

ISISC H 118 L 56 P 7/35

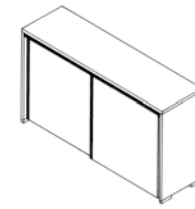

E1050S H 105 L 150 P 51
E1050L H 105 L 200 P 51

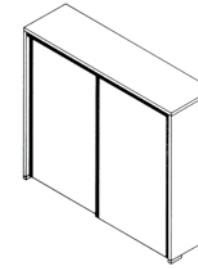

E1630S H 163 L 150 P 51
E1630L H 163 L 200 P 51

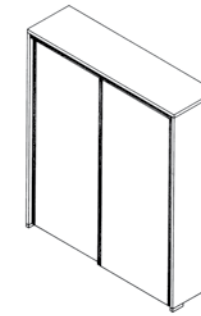

E2100S H 210 L 150 P 51
E2100L H 210 L 200 P 51

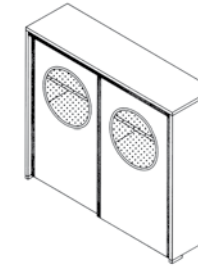

E1631S H 163 L 150 P 51
E1631L H 163 L 200 P 51

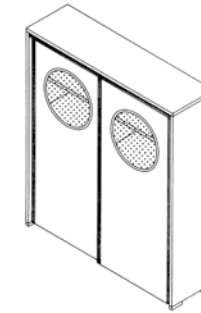

E2101S H 210 L 150 P 51
E2101L H 210 L 200 P 51

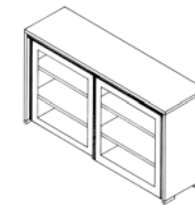

E1052S H 105 L 150 P 51
E1052L H 105 L 200 P 51

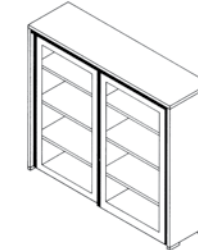

E1632S H 163 L 150 P 51
E1632L H 163 L 200 P 51

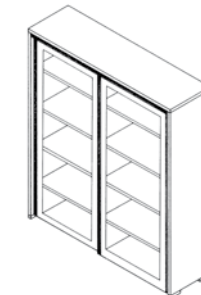

E2102S H 210 L 150 P 51
E2102L H 210 L 200 P 51



E1058 H 105 L 95 P 51



E1638 H 163 L 95 P 51



E2108 H 210 L 95 P 51

isotta

EKLISS
SCORRERE