



# MEDLEY

La sequenza di note che creano una melodia, il variare dei colori e l'alternarsi dei materiali su differenti superfici, riflessi e motivi per una sintesi di perfetta eufonia.

*The sequence of notes that create a melody, the changing of colors and the alternation of materials on different surfaces, reflections and patterns for a perfect synthesis of euphony.*

*La séquence de notes qui créent une mélodie, la variation des couleurs et l'alternance des matériaux sur des surfaces, des reflets et des motifs différents pour une synthèse d'euphonie parfaite.*

## COLORI E MATERIALI



N2RO

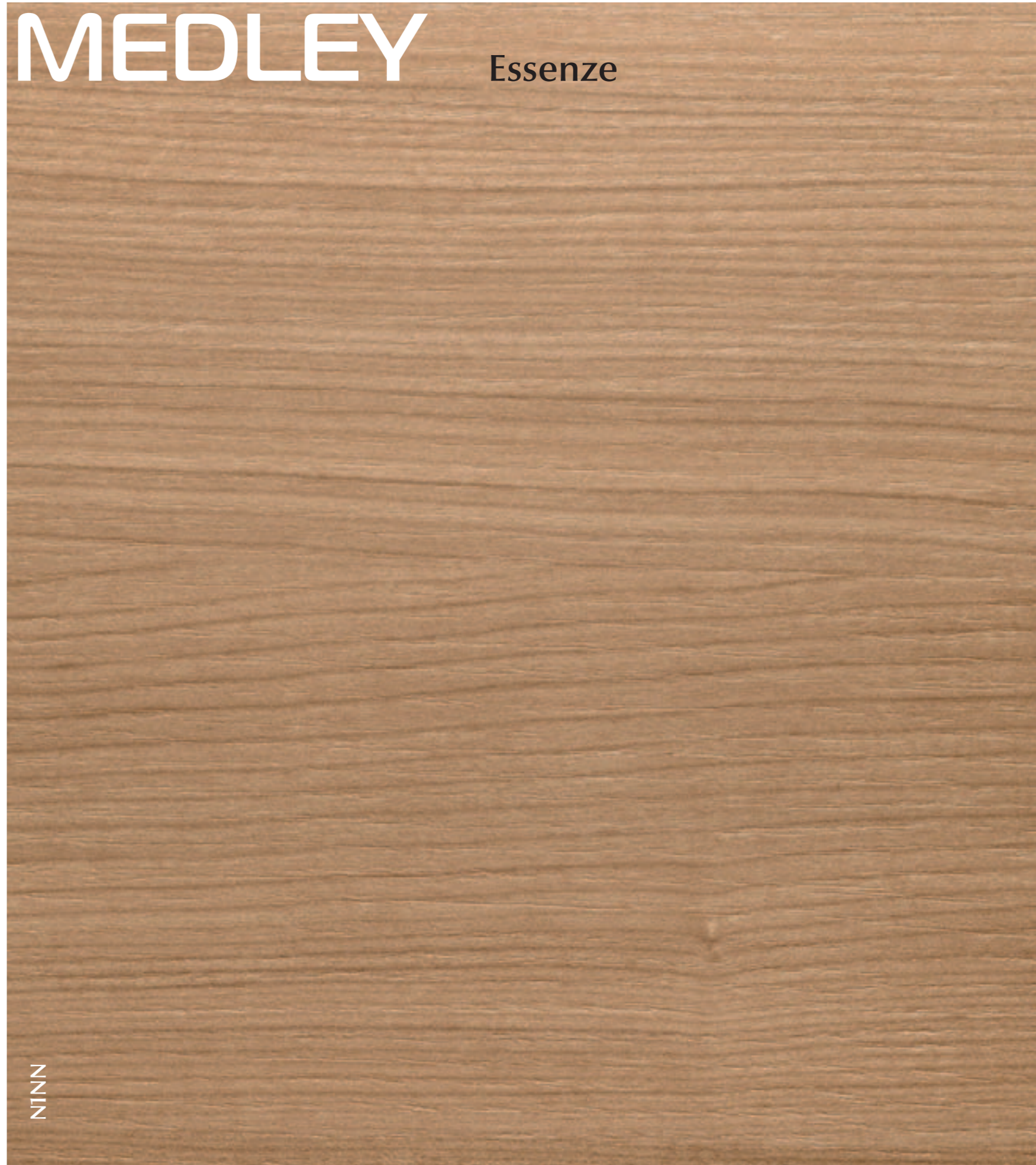

# MEDLEY

Essenze

N1IN



N3RT



N2WE



N3RF



N2NO



NTAS



N3NS



N3CB



N3LG



Essenze

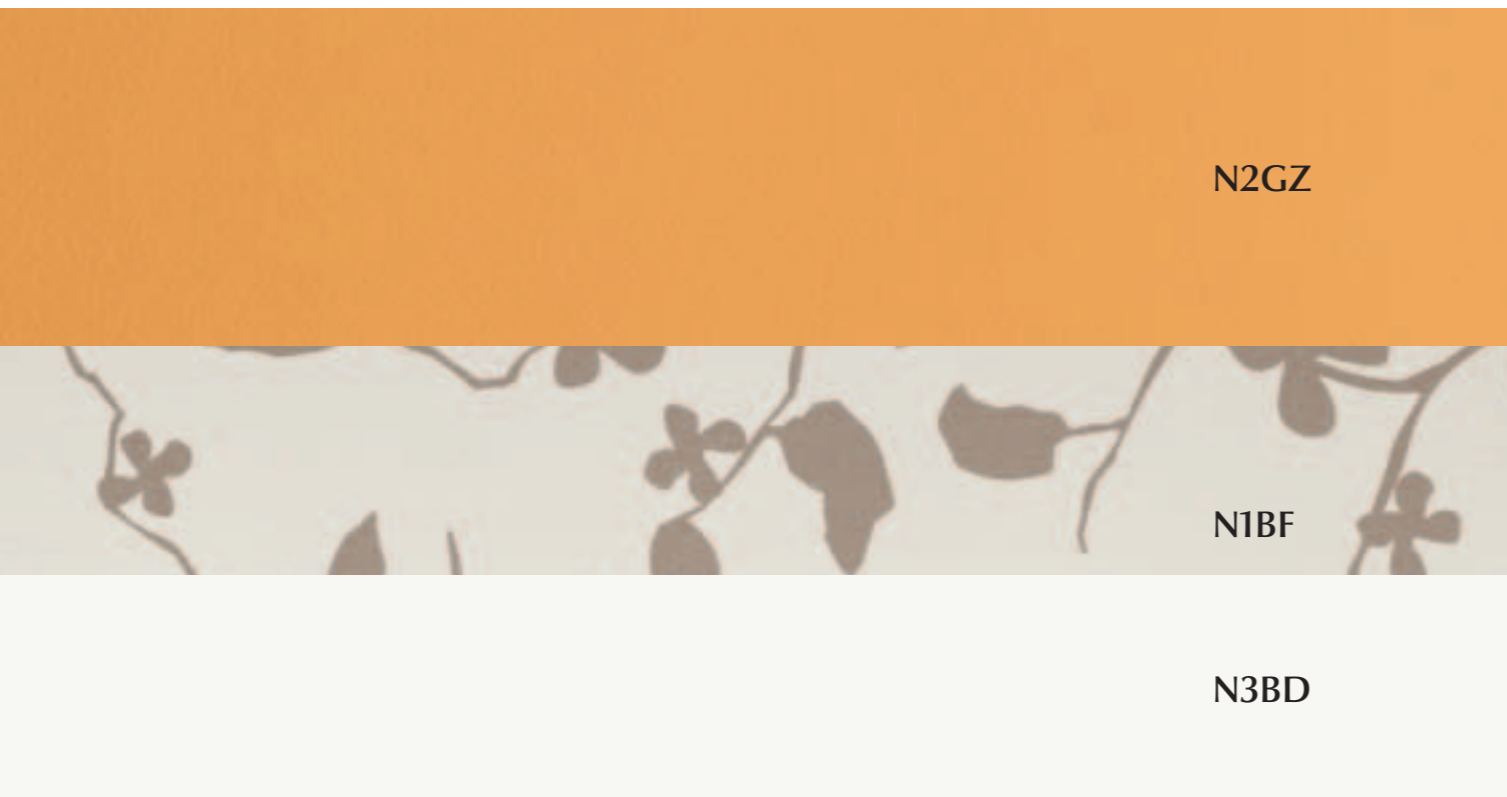
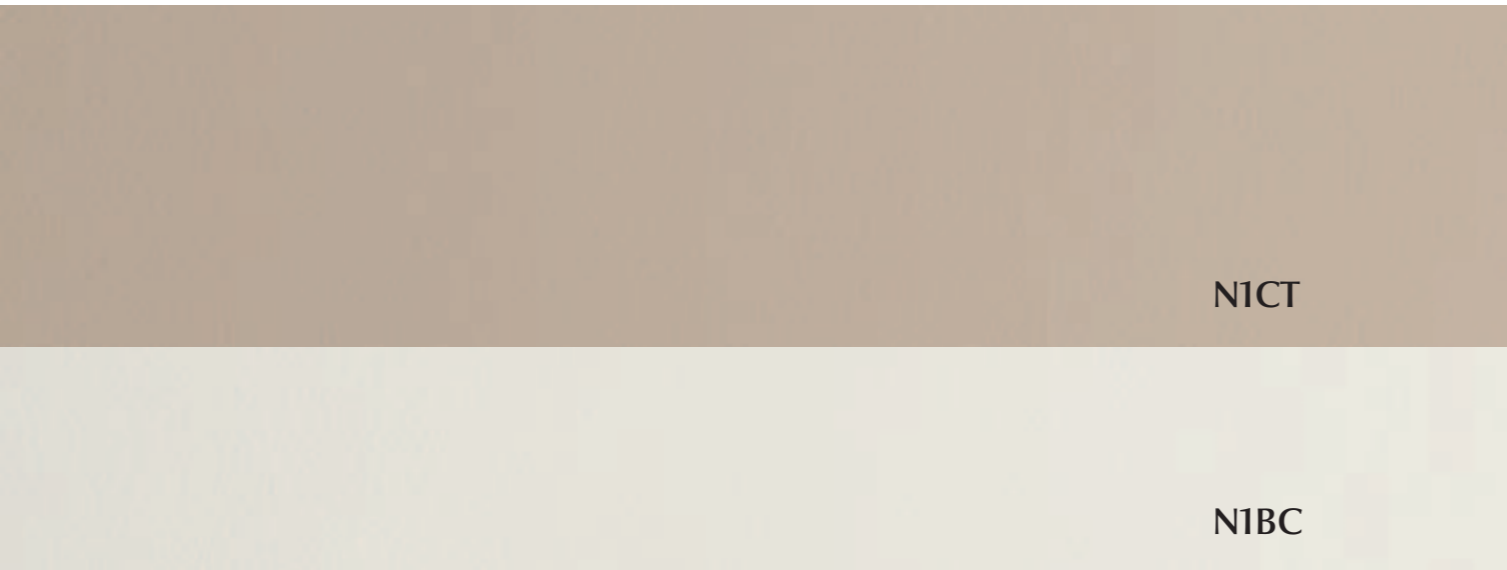

# MEDLEY

Types Essences

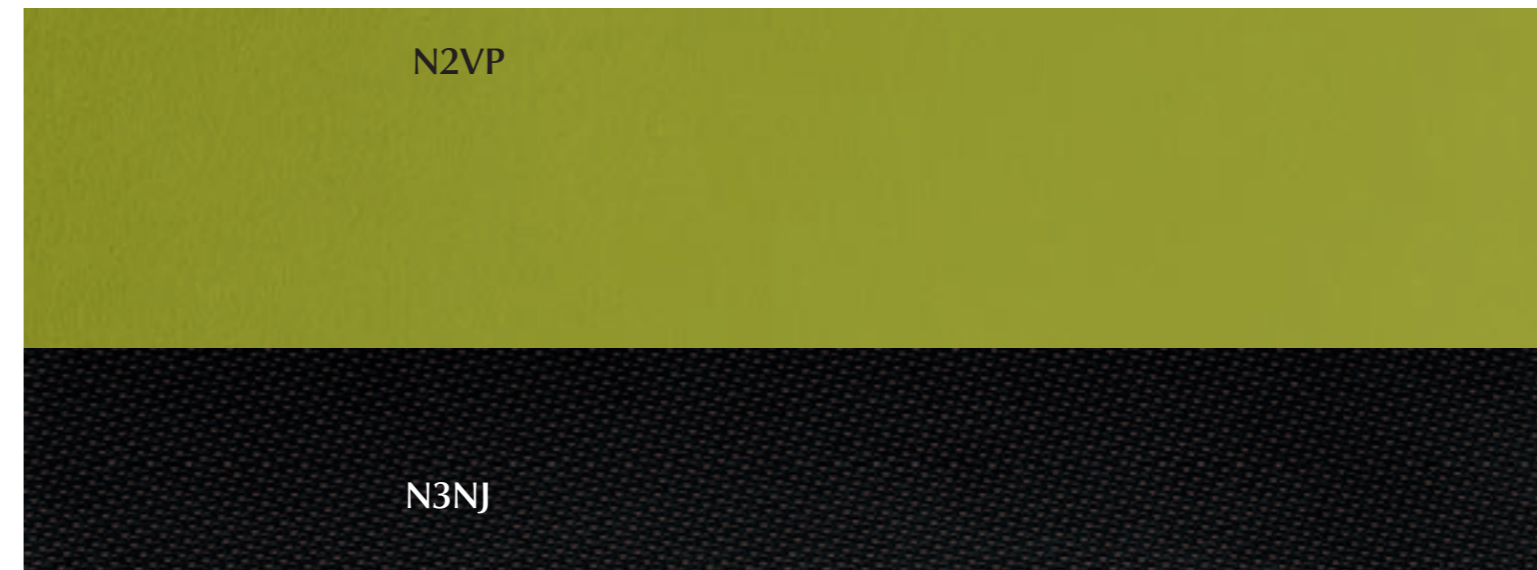
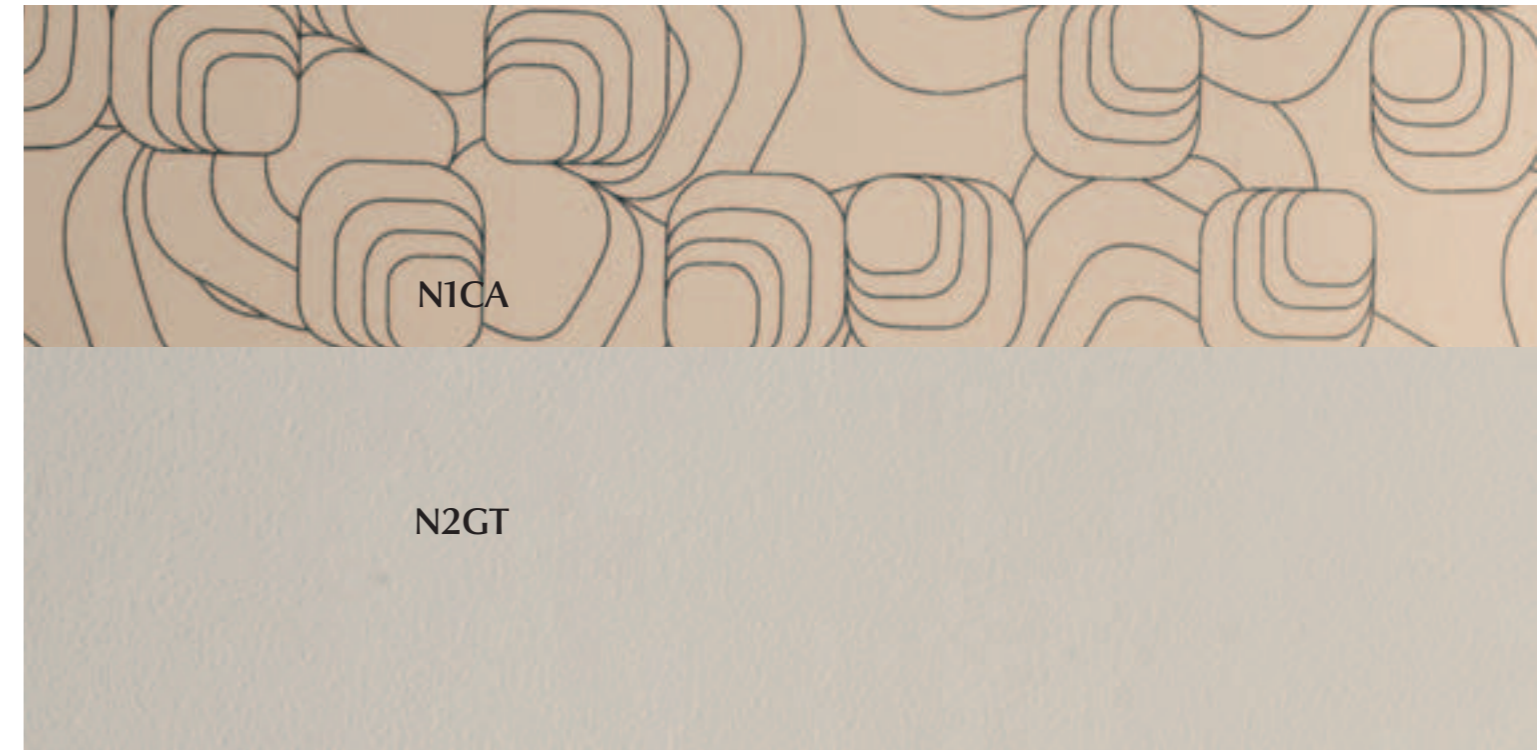



Laccati opachi



MEDLEY Opaque Painted Laqués Opaques

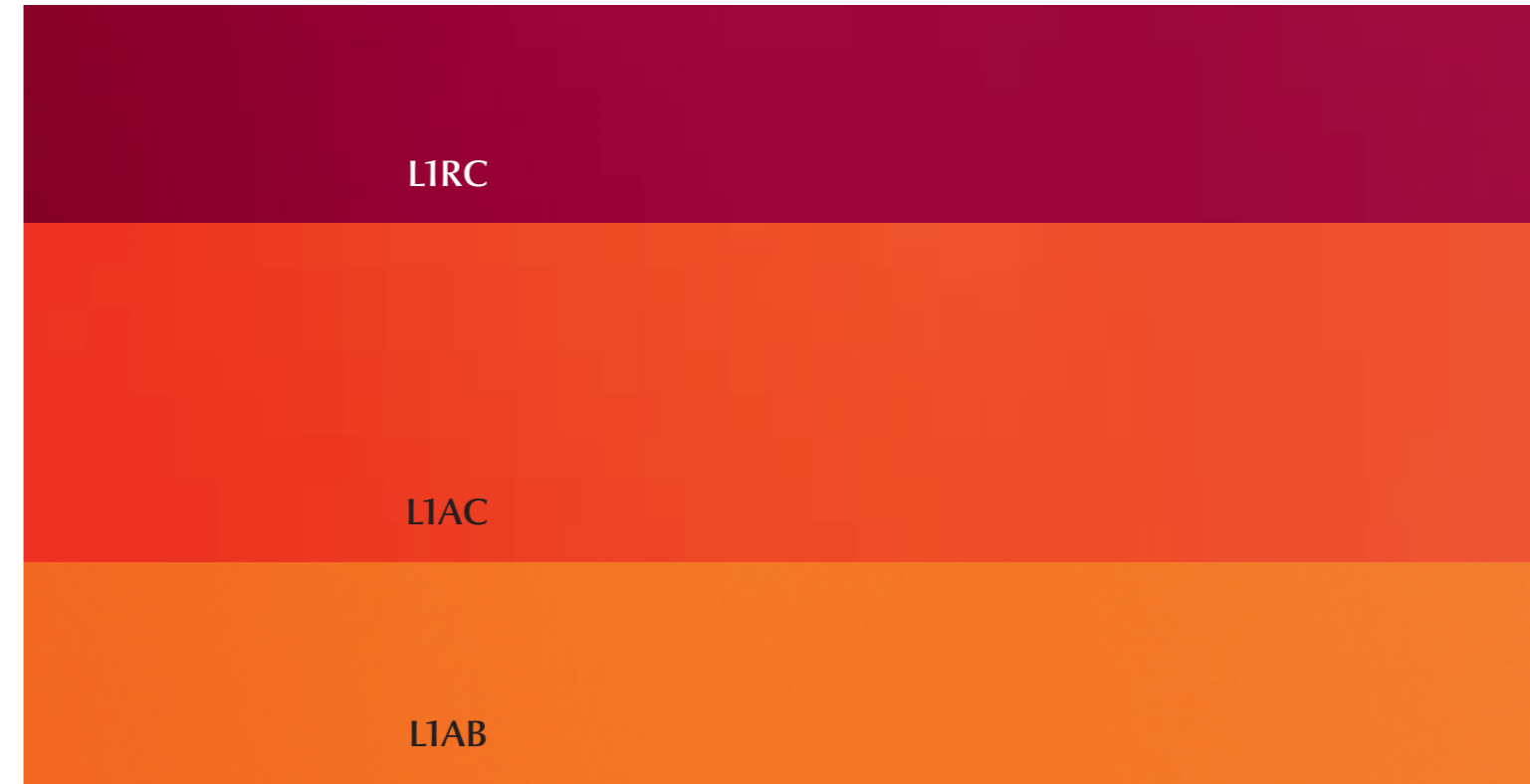

## Laccati opachi



1004 ral

1012 ral

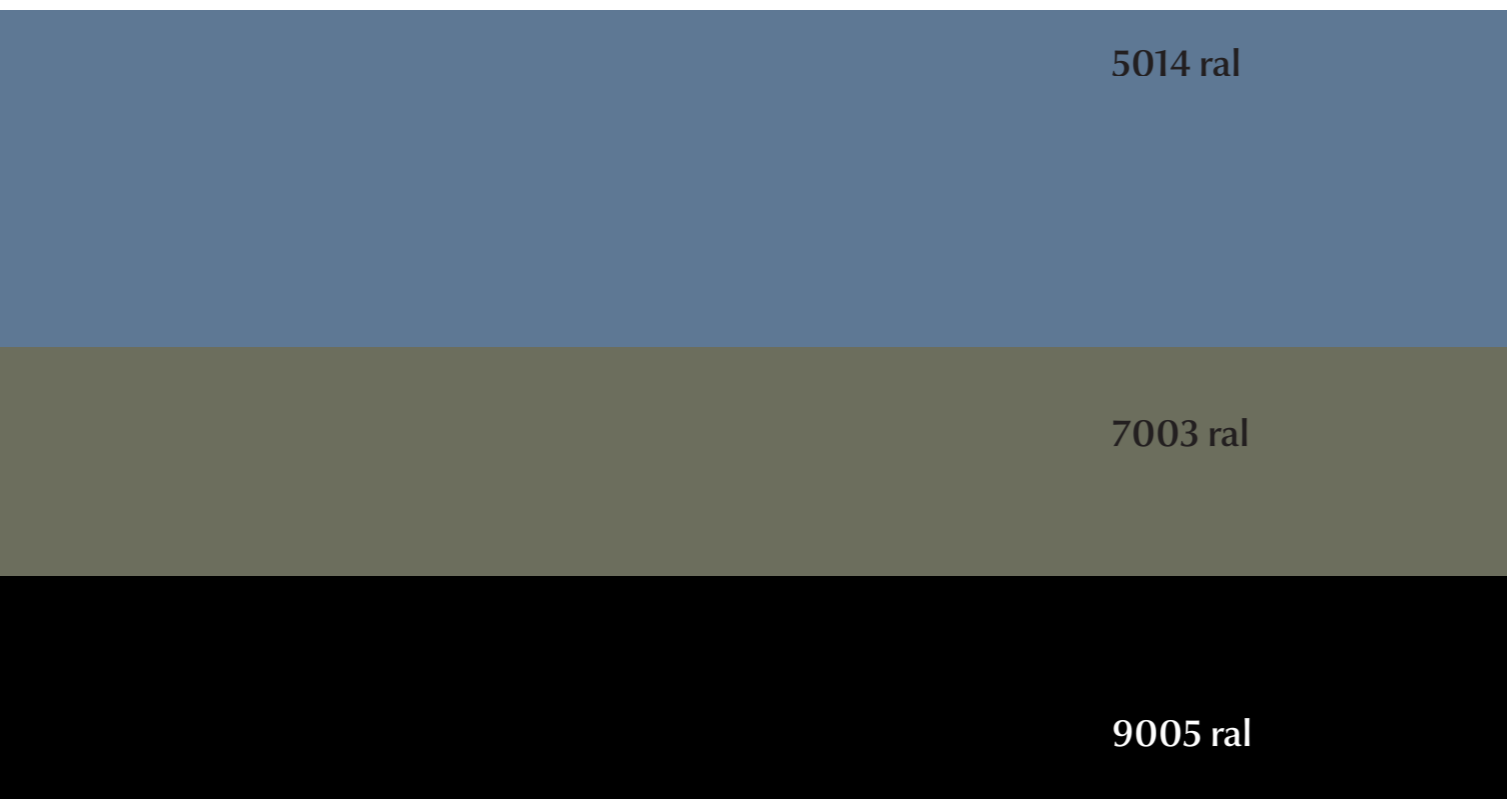

5014 ral

7003 ral

9005 ral

## MEDLEY Opaque Painted Laqués Opaques



3002 ral

7022 ral

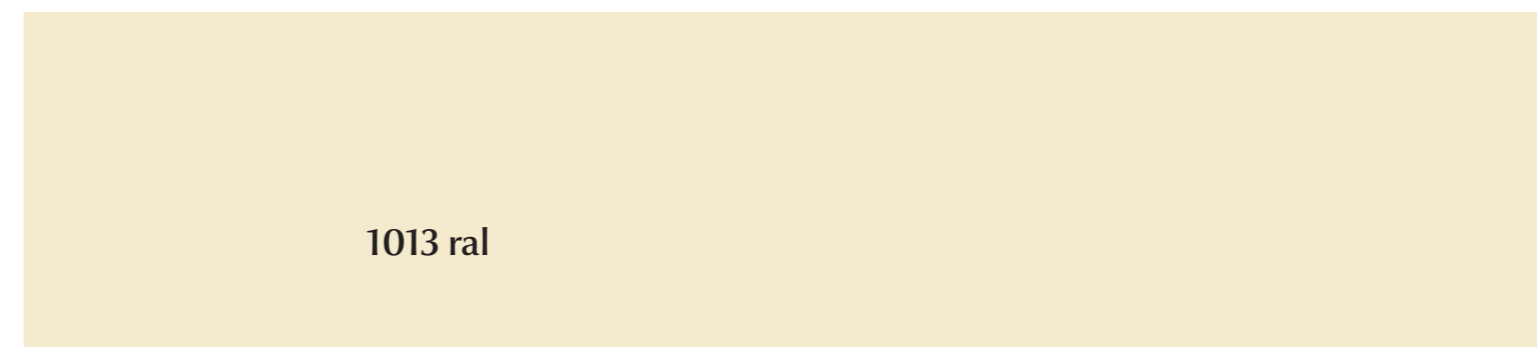

1013 ral

Laccati lucidi

# MEDLEY High Glossy Painted Laqués Polis

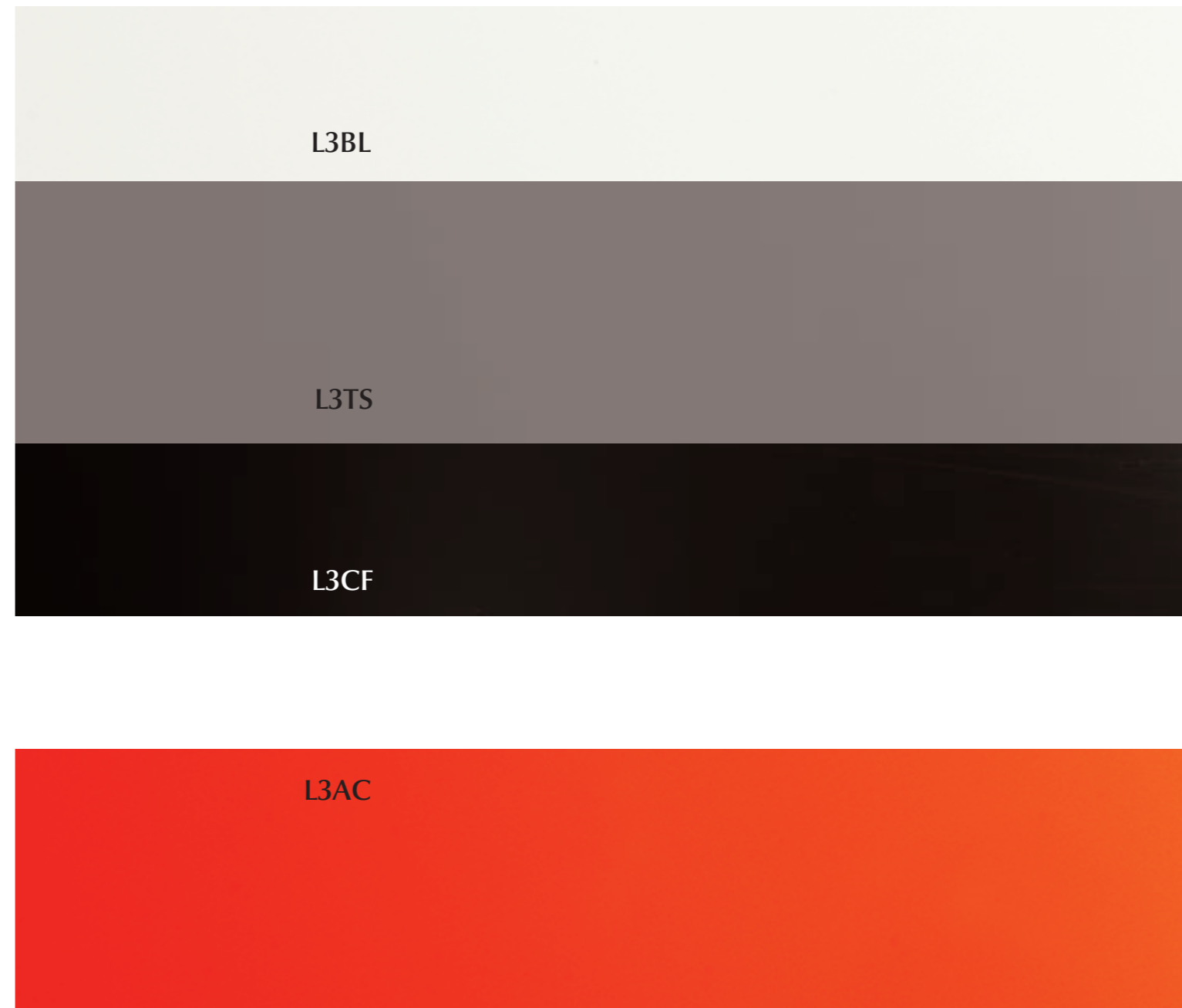

Metallo

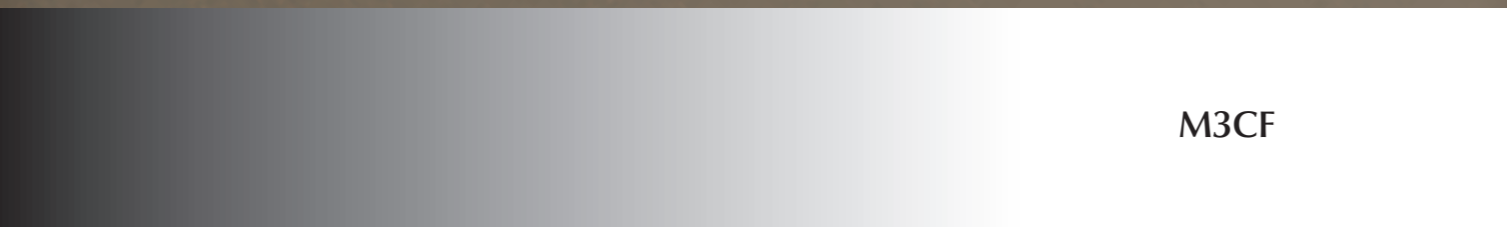

MEDLEY Metal Métal

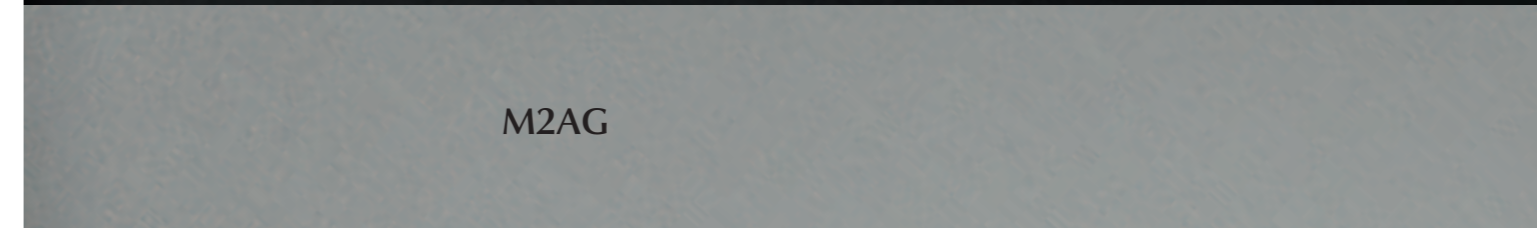
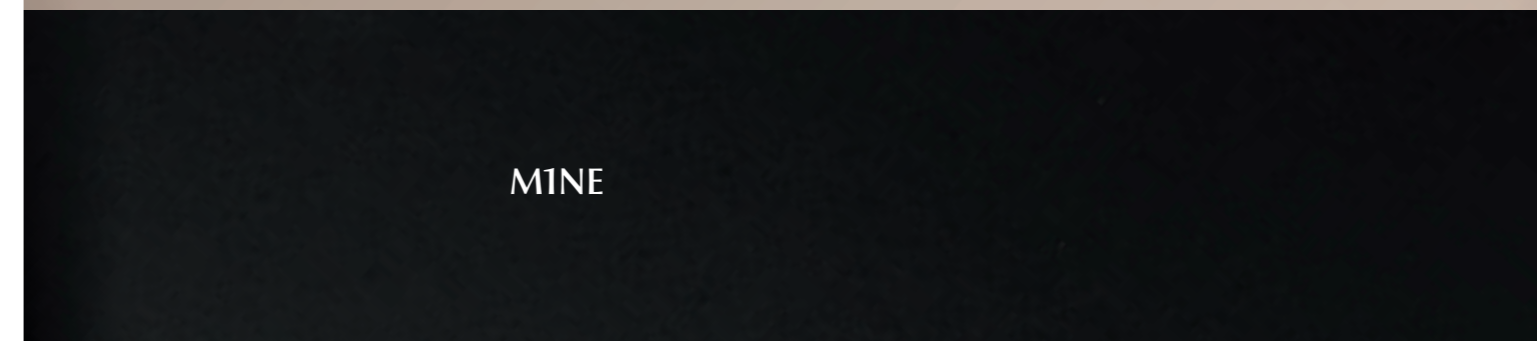
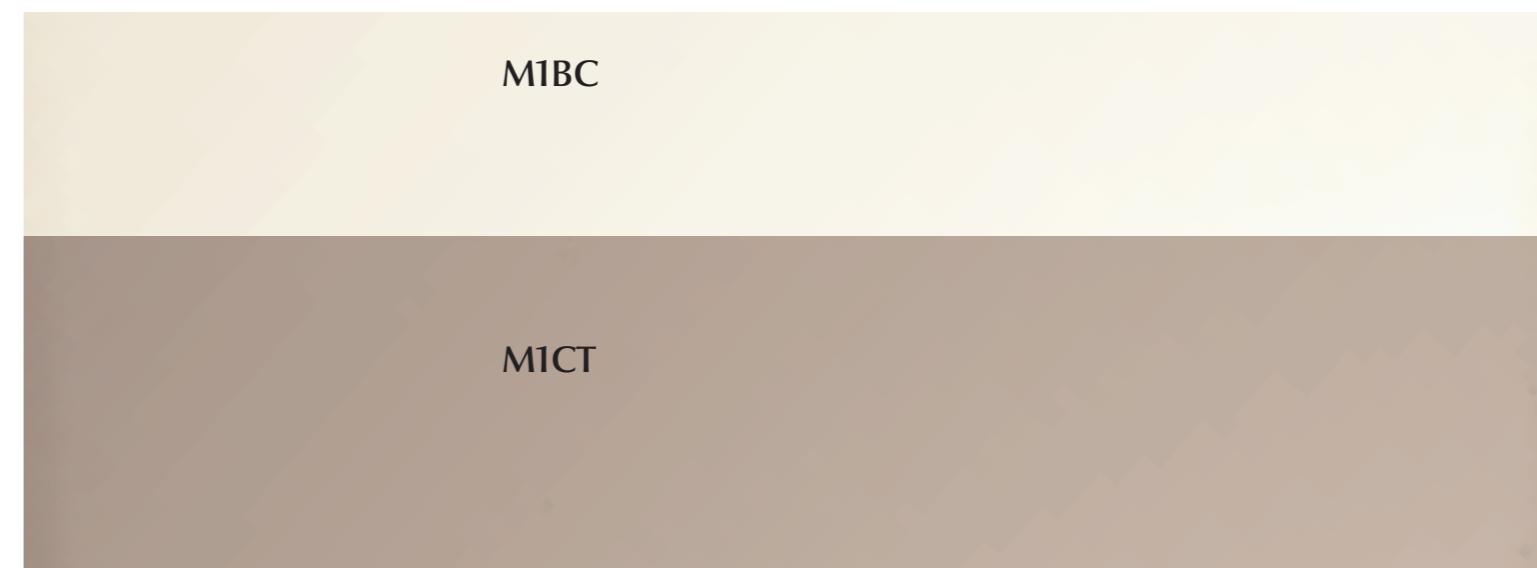

Vetri



MEDLEY Glasses Verres

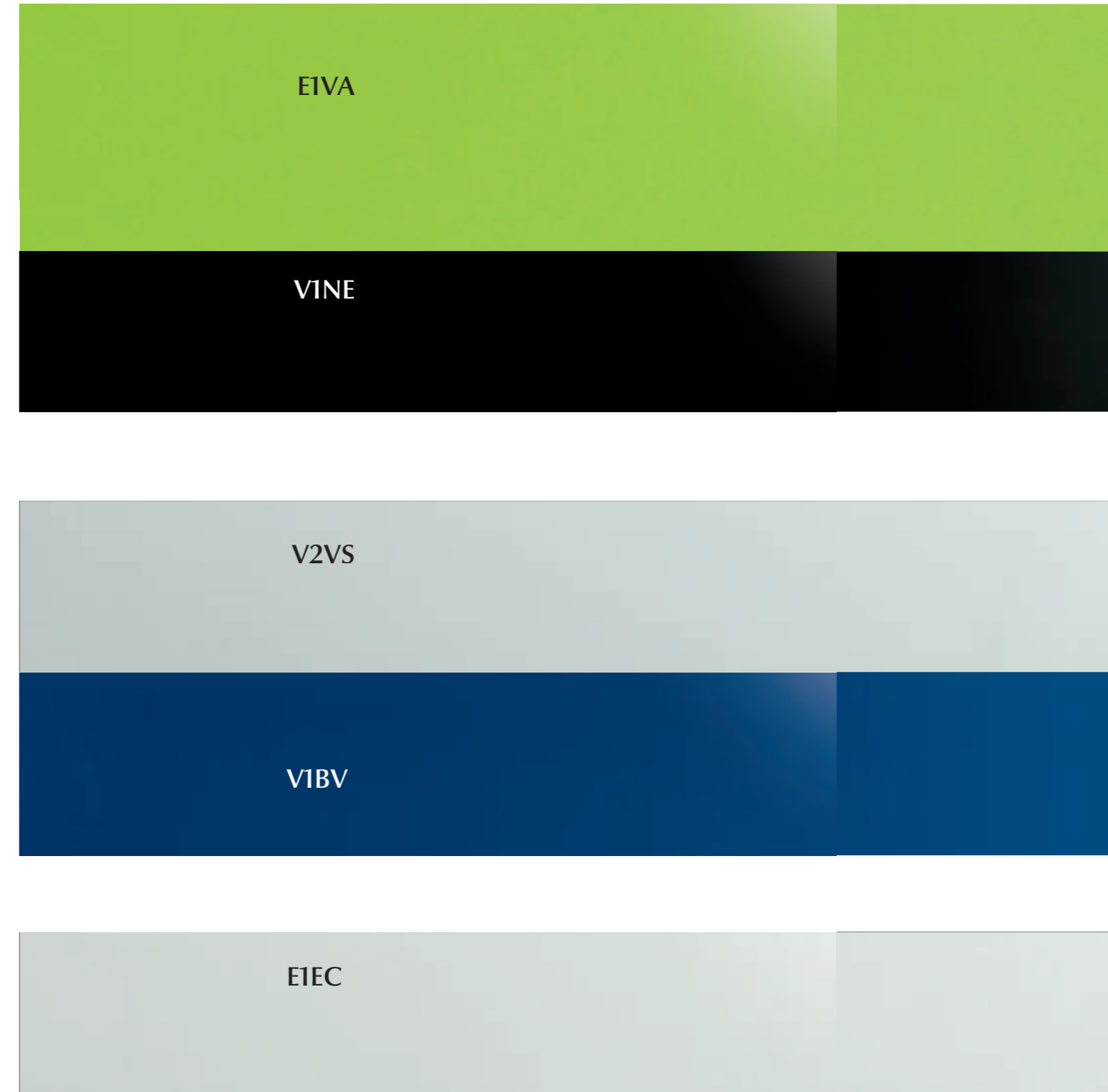

Tessuti

MEDLEY Fabrics Tissés

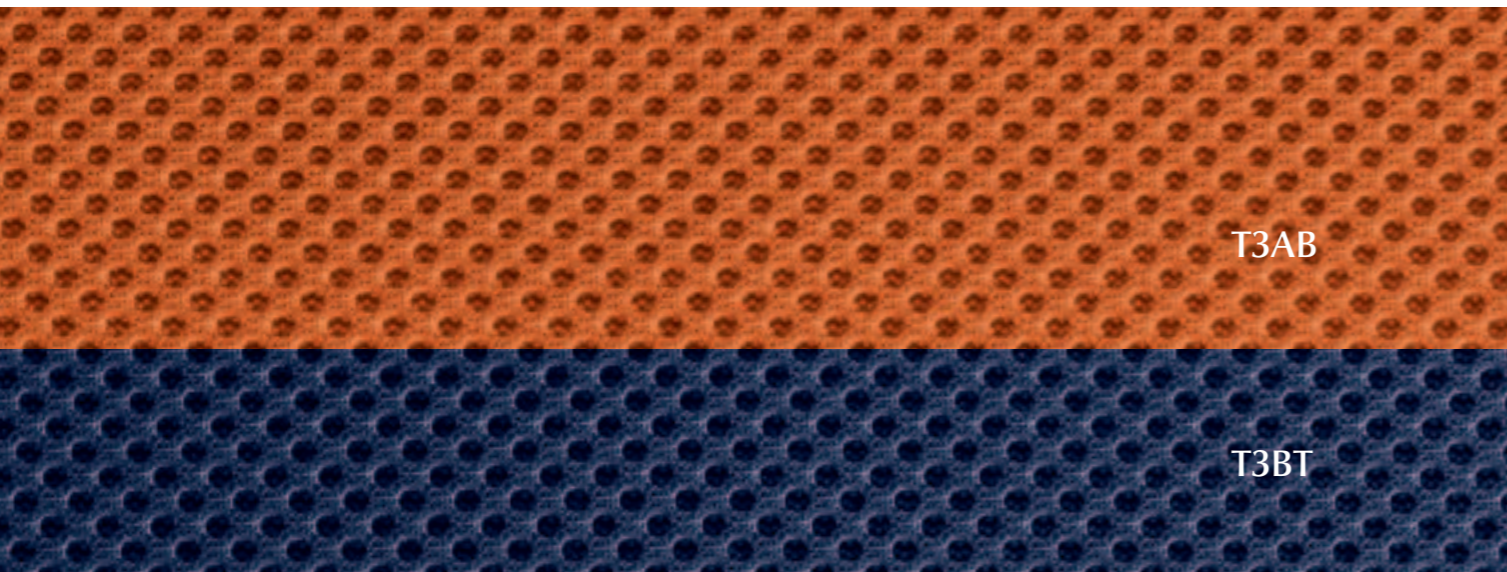

T3AB

T3BT

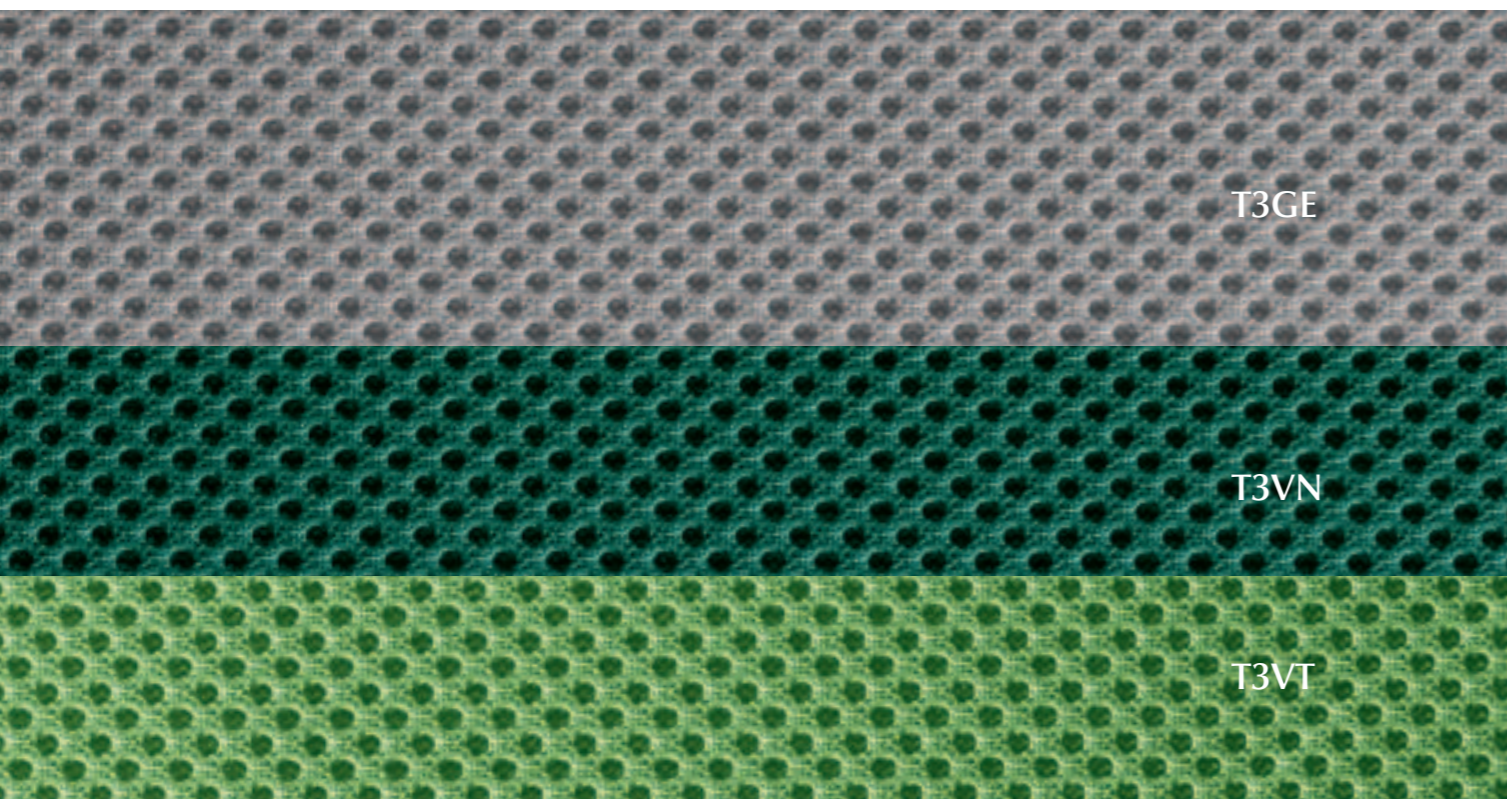

T3GE

T3VN

T3VT



T3RT



T3BA

T3GN



T3AA

T3NO





# MEDLEY

L'improvviso comparire di una nota che rende compiuta la sinfonia, l'accordo più intonato a strutture e materiali. La maniglia per frontali e contenitori, come una chiave all'inizio del pentagramma, rende il tono di tutta la sequenza e anticipa già la chiusa finale.

*The sudden appearance of a note that makes the symphony completed and an agreement more in tune to structures and materials. The handle for front doors and containers as a key that starts the stave and gives life to the tone of the entire sequence, anticipating its final ending.*

*L'apparition soudaine d'une note qui achève la symphonie, l'accord plus assorti aux structures et aux matériaux. La poignée pour les parties avant et les caissons, telle une clé au début d'un pentagramme, donne la tonalité de toute la séquence et anticipe déjà son dénouement final.*

## PROPOSTA MANIGLIE



# MEDLEY

Maniglie cromate/satinate  
Chromed/satinated handles  
Poignée chromée/satinée

Interasse 320mm  
Measurement 320mm  
Mesure 320mm

Interasse 160mm  
Measurement 160mm  
Mesure 160mm

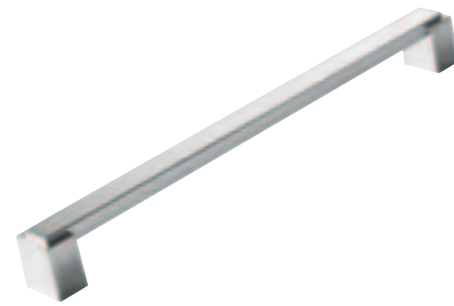

MEEE911

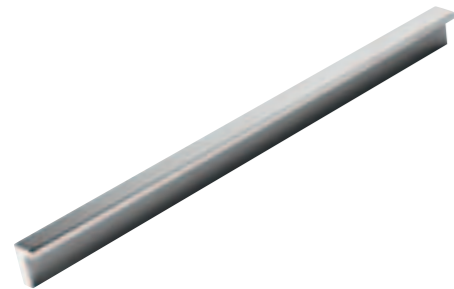

MEEE912



MEEE913

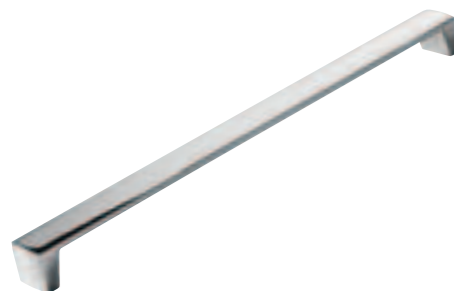

MEEE914



MEEE915



MEEE901

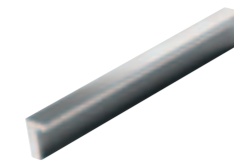

MEEE902



MEEE903



MEEE904



MEEE905

## INFORMAZIONE TECNICA

**I frontali US** dei contenitori (cassettiere, mobili di servizio, ante legno, ante vetro, mobili portanti) nelle finiture NIBC, NICT, NIAS, NINN, NIBF, NICA vengono forniti standard con maniglia US in alluminio argento lucido.

**I frontali FU** dei contenitori (cassettiere, ante legno, ante vetro) nelle finiture N2GT, N2RO, N2NO, N2WE vengono forniti standard con maniglia FU in Zamak verniciata finitura alluminio.

**I frontali ME** dei contenitori (cassettiere, mobili di servizio, ante legno, ante vetro, mobili portanti) nelle finiture N3NS, N3LG, N3RT, N3RF, N3CB vengono forniti senza maniglia con la possibilità di scegliere una tra le dieci differenti proposte di maniglie cromate. Per facilitare l'abbinamento cassetiera e ante con maniglia a scelta è disponibile un modello di cassetiera senza maniglia frontale ma con presa invisibile laterale.

Ulteriori dettagli sono riportati sul listino tecnico.

## TECHNICAL INFORMATION

**The US front elements** of the modular shelving units (pedestals, service units, blind doors, glass doors, supporting containers) with finishes NIBC, NICT, NIAS, NINN, NIBF, NICA are supplied with standard US handles in glossy silver finished aluminium.

**The FU front elements** of the modular shelving units (pedestals, blind doors, glass doors) with finishes N2GT, N2RO, N2NO, N2WE are supplied with standard FU handles made of Zamak with aluminium painting.

**The ME front elements** of the modular shelving units (pedestals, service units, blind doors, glass doors, supporting containers) with finishes N3NS, N3LG, N3RT, N3RF, N3CB are supplied without standard handle with the option to choose one of 10 available chrome finished ME handles.

To facilitate the matching of pedestals with fronts of modular shelving units (with optional choice of handle), there is a pedestal without handles on the front (including recessed side handle on the drawer fronts).

Further details are available on the technical price list.

## DESCRIPTION

**Le parties avant US** des caissons (caissons à tiroirs, meubles de service, portes en bois, portes en verre, meubles portant) dans les finitions NIBC, NICT, NIAS, NINN, NIBF, NICA sont équipées de poignées US en aluminium argenté brillant.

**Les parties avant FU** des caissons (caissons à tiroirs, portes en bois, portes en verre) dans les finitions N2GT, N2RO, N2NO, N2WE sont équipées de poignées FU en Zamak peintes et finition en aluminium.

**Les parties avant ME** des caissons (caissons à tiroirs, meubles de service, portes en bois, portes en verre, meubles portant) dans les finitions N3NS, N3LG, N3RT, N3RF, N3CB ne sont pas munies de poignée et il y a la possibilité de choisir une des dix différentes propositions de poignées chromées.

Afin de faciliter la combinaison du caisson avec ses portes, avec poignée au choix, nous vous proposons un modèle de caisson sans poignée frontale mais dispose de poignée latérale invisible.

Pour plus d'informations, consultez la brochure.

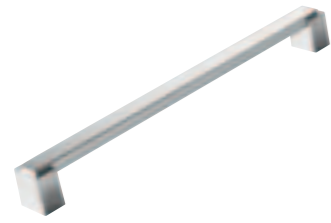

**MEEE911** | Interasse 320mm  
Measurement 320mm  
Mesure 320mm

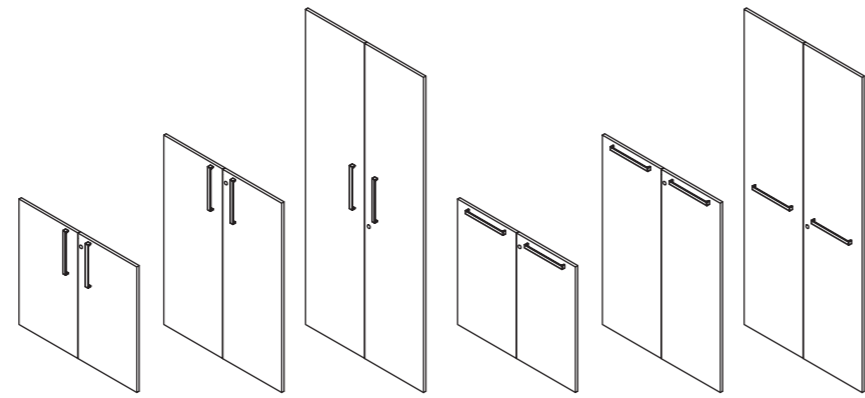

**MEEE901** | Interasse 160mm  
Measurement 160mm  
Mesure 160mm

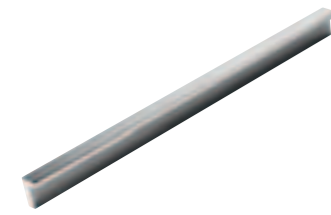
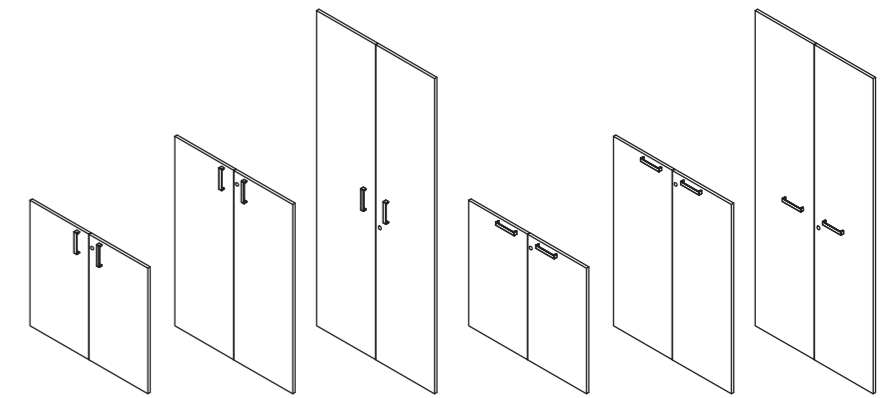

**MEEE912** | Interasse 320mm  
Measurement 320mm  
Mesure 320mm

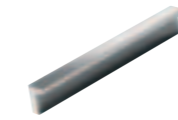
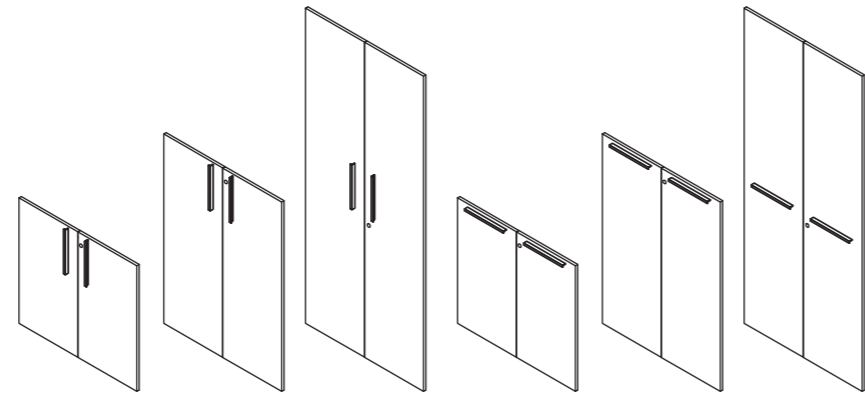

**MEEE902** | Interasse 160mm  
Measurement 160mm  
Mesure 160mm

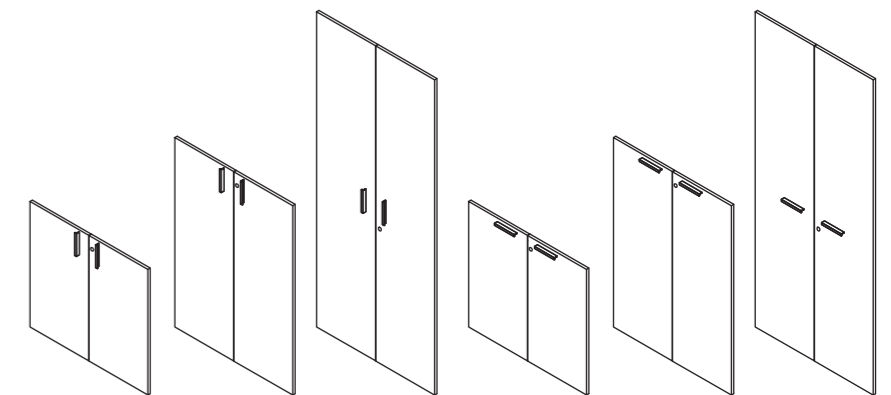

**MEEE913** | Interasse 320mm  
Measurement 320mm  
Mesure 320mm

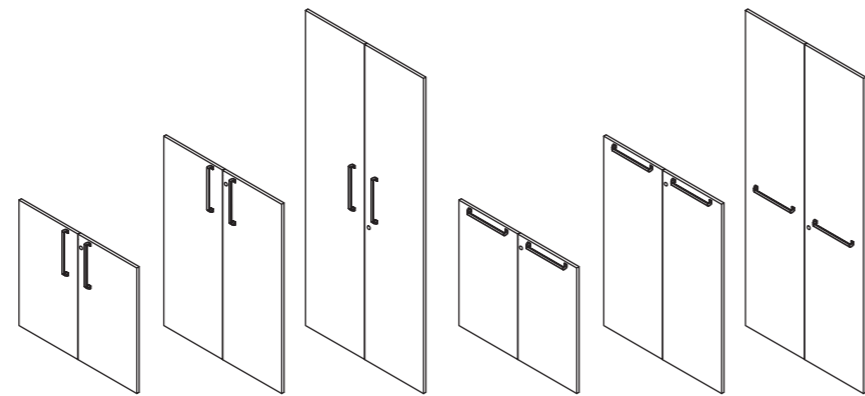

**MEEE903** | Interasse 160mm  
Measurement 160mm  
Mesure 160mm

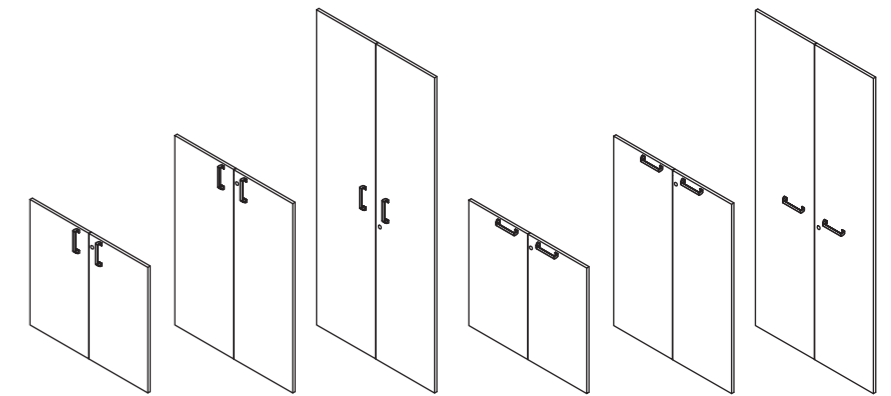

**MEEE914** | Interasse 320mm  
Measurement 320mm  
Mesure 320mm

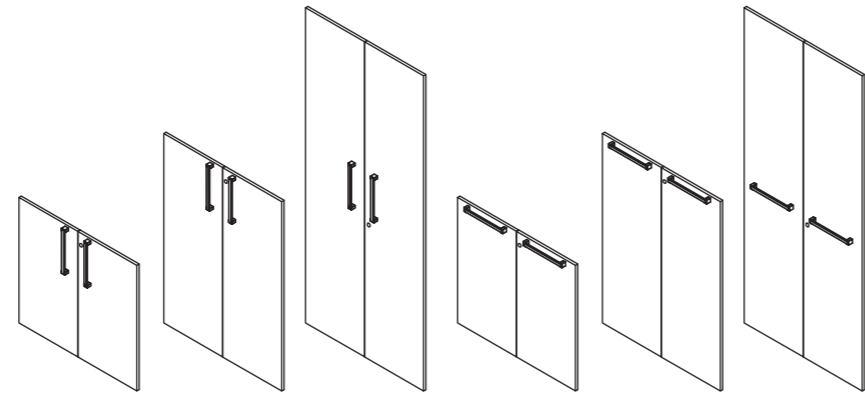

**MEEE904** | Interasse 160mm  
Measurement 160mm  
Mesure 160mm

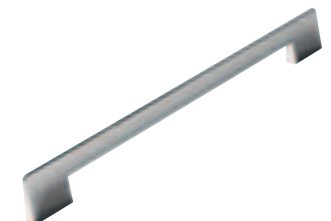
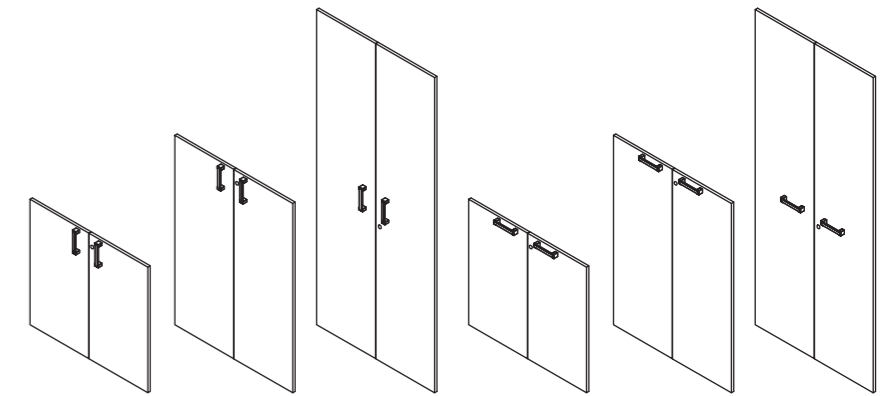

**MEEE915** | Interasse 320mm  
Measurement 320mm  
Mesure 320mm

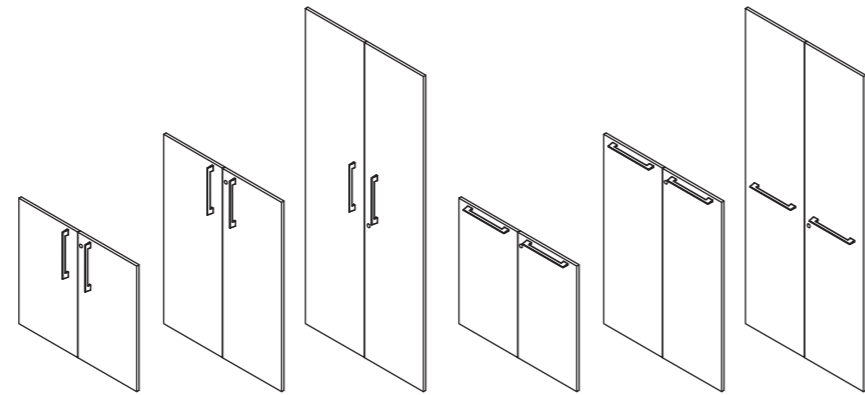

**MEEE905** | Interasse 160mm  
Measurement 160mm  
Mesure 160mm

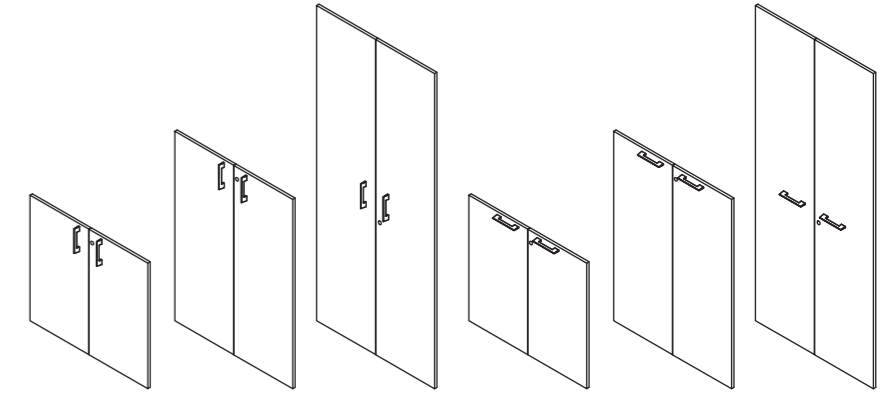



# MEDLEY

Una sinfonia di forme, dimensioni e colori per comporre la vostra armonia, scegliendo finiture e materiali nell'ampia gamma di possibilità che Medley vi offre.

*A symphony of shapes, sizes and colors to make up your harmony, choosing finishes and materials in the wide range of possibilities that Medley offers.*

*Une symphonie de formes, dimensions et couleurs pour créer votre harmonie grâce au choix dans les finitions et les matériaux de la vaste gamme proposée par Medley.*

## TAVOLE DI ABBINABILITÀ

\* Per maggiori dettagli, consultare il listino tecnico

\* *Further details are available on the technical price list. / Pour plus d'information, consultez la brochure.*

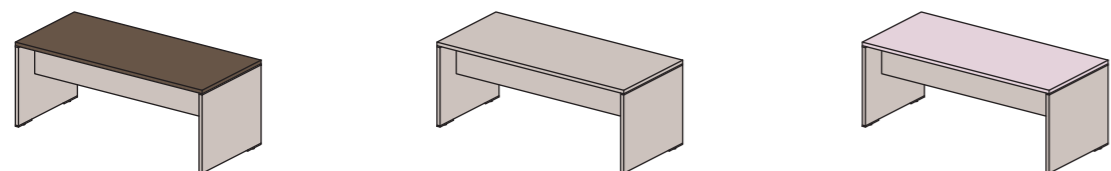

Variazioni sul piano scrivania.  
Variation of desk top.  
Variations du plan de bureau.

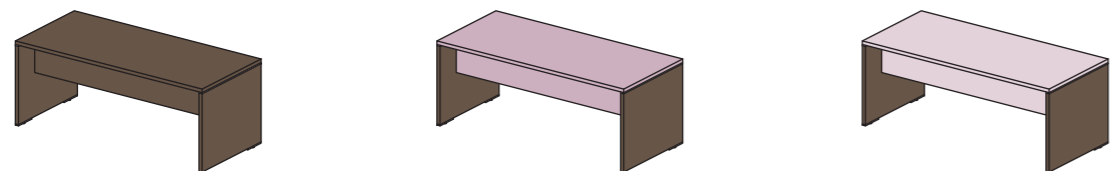

Variazioni sul piano scrivania e gonna.  
Variation of desk top and modesty panel.  
Variations du plan de bureau et du panneau avant..

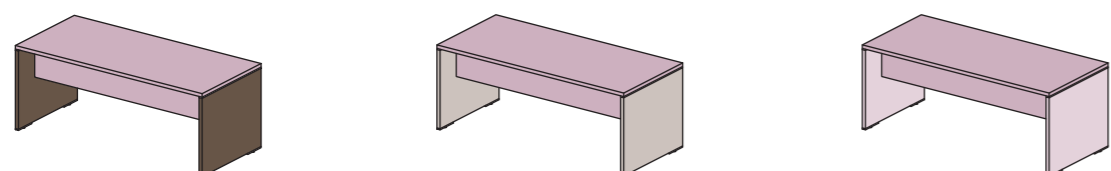

Variazioni su fianchi scrivania.  
Variation of desk side panels.  
Variations des côtés du bureau.

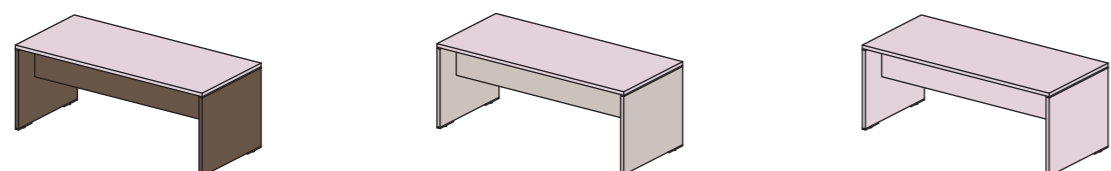

Variazioni su gonna e fianchi scrivania.  
Variation of modesty panel and desk side panels.  
Variations du panneau avant et des côtés du bureau.

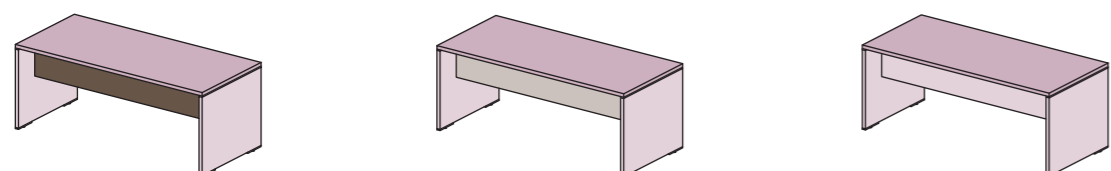

Variazioni su gonna.  
Variation of modesty panel.  
Variations du panneau avant.

# MEDLEY

Piano lineare e struttura legno  
Straight desk top and wooden structure  
Plan linéaire et structure en bois

Nella pagina sinistra: tavola sinottica con alcuni possibili esempi di variazioni finitura. In questa pagina: disegno con riferimenti esplicativi per la disponibilità finitura/ colore per elemento.  
A= piano lavoro, B= struttura

On the left: overview table with some examples of possible variations of finishes. On this page: drawing with explanation reference of availability finish/ color for item.  
A= desk top, B= structure

Dans la page de gauche: tableau synoptique avec quelques exemples de variations des finitions. Dans cette page: dessin avec des références explicatives sur la disponibilité finitions/couleur de l'objet.  
A= plan de travail, B= structure

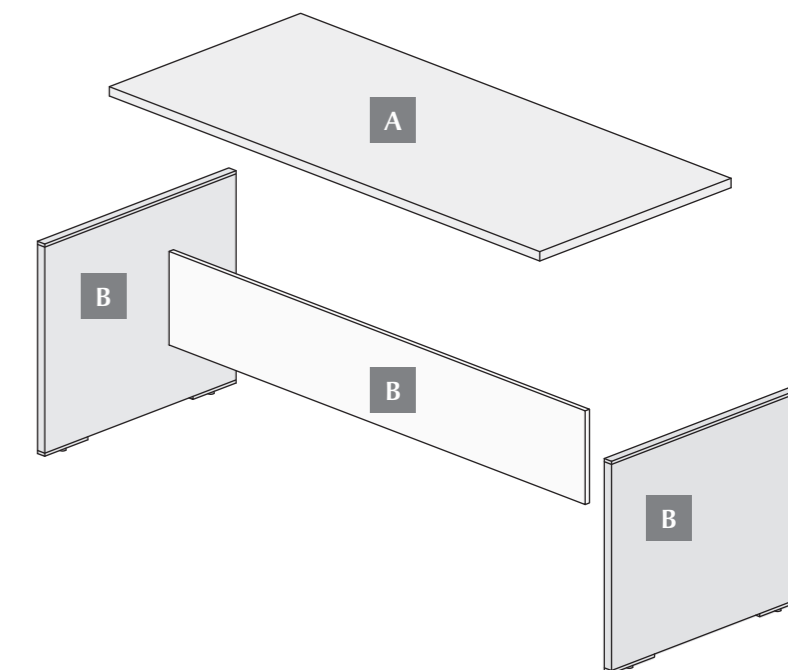

FINITURE MELAMINICO MFC FINISHES FINITION EN MELAMINE		N1BC	N1AS	N1CT	N1NN	N2GT	N2RO	N2NO
FINITURE MELAMINICO MFC FINISHES FINITION EN MELAMINE		N2WE	N2GZ	N2VP				
FINITURE LACCATO OPACO OPAQUE PAINTED FINISHES FINITION LAQUES OPAQUES		L_TS	L_MC	L_CL	L_RC	L_AC	L_AB	L_SD
		L_VA	L_BV	L_GS	L_CR	___ral		

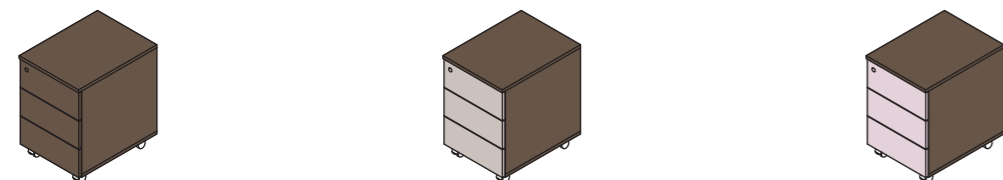
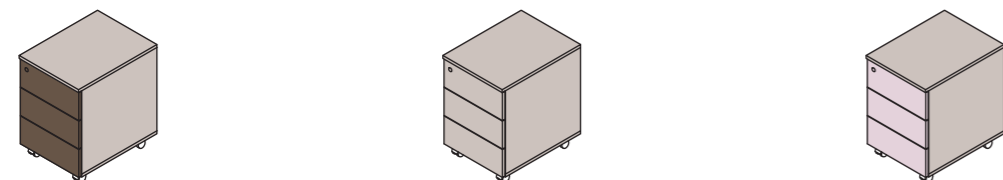

Variazioni sui frontali cassetiera.  
Variation of drawer fronts.  
Variations des parties avant du caisson.

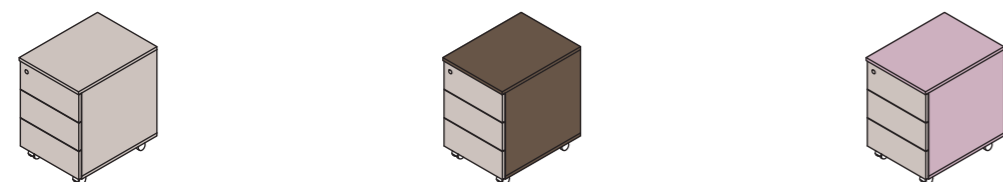
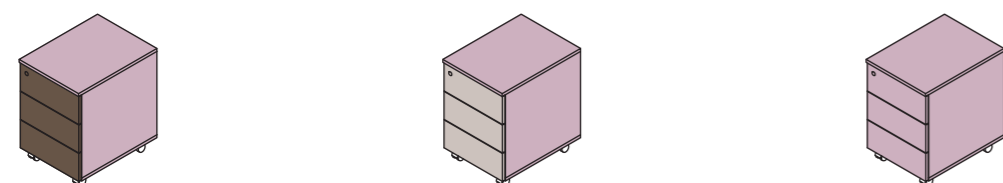

Variazioni su struttura cassetiera.  
Variation of structure of pedestal.  
Variations de la structure du caisson.

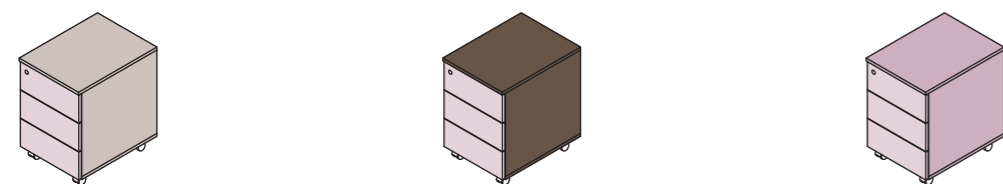

# MEDLEY

Cassetiera in melaminico  
MFC pedestal  
Caisson en mélamine

Nella pagina sinistra: tavola sinottica con alcuni possibili esempi di variazioni finitura. In questa pagina: disegno con riferimenti esplicativi per la disponibilità finitura/ colore per elemento.  
A= struttura, B= frontali

On the left: overview table with some examples of possible variations of finishes. On this page: drawing with explanation reference of availability finish/ color for item.  
A= structure, B= front elements

Dans la page de gauche: tableau synoptique avec quelques exemples de variations des finitions. Dans cette page: dessin avec des références explicatives sur la disponibilité finition/couleur de l'objet.  
A=structure, B= parties avant

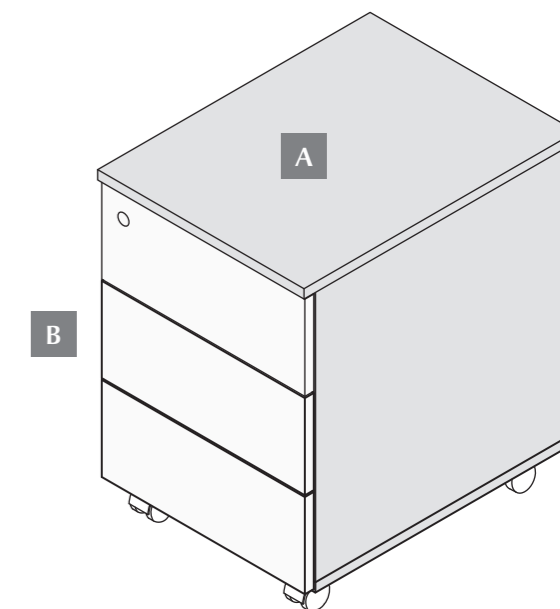

FINITURE MELAMINICO  
MFC FINISHES  
FINITION EN MELAMINE



FINITURE MELAMINICO  
MFC FINISHES  
FINITION EN MELAMINE



FINITURE LACCATO OPACO  
OPAQUE PAINTED FINISHES  
FINITION LAQUES OPAQUES

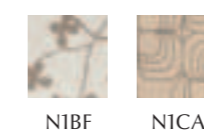



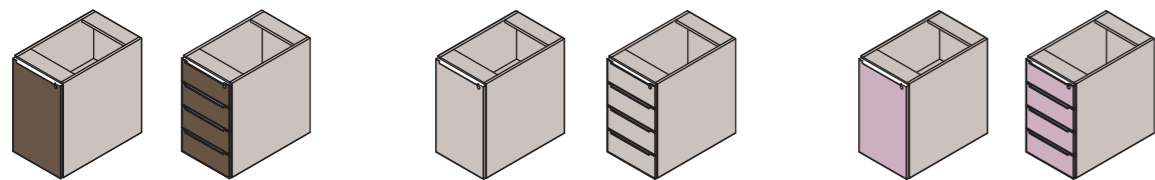

Variazioni su frontali con struttura in melaminico (senza top per uso sotto piano).  
 Variation of front elements with MFC structure (without top for use under work top)  
 Variations des parties avant avec structure en mélamine (sans plan de travail pour utilisation sous-plan)

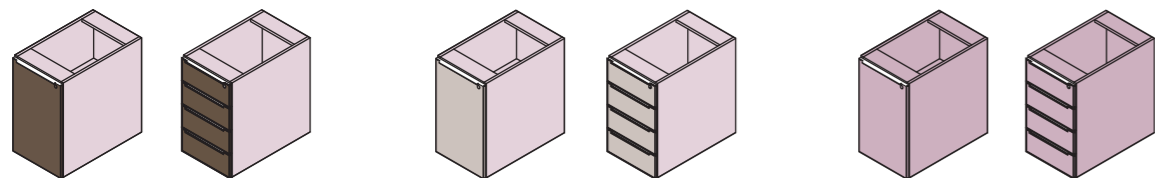

Variazioni su frontali con struttura laccata (senza top per uso sotto piano).  
 Variation of front elements with painted structure (without top for use under work top)  
 Variations des parties avant avec structure laquée (sans plan de travail pour utilisation sous-plan)

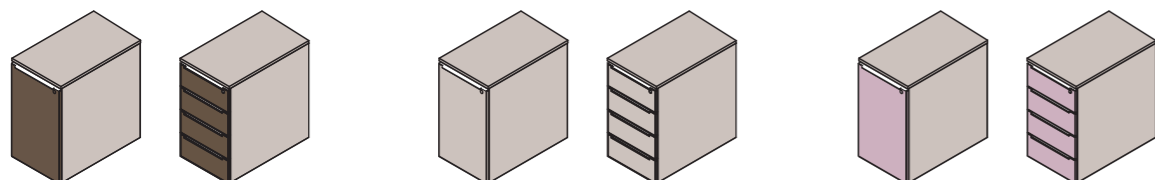

Variazioni su frontali con struttura e top finitura in melaminico.  
 Variation of front elements with MFC structure and top.  
 Variations des parties avant, structure et plan de travail avec finition en mélamine.

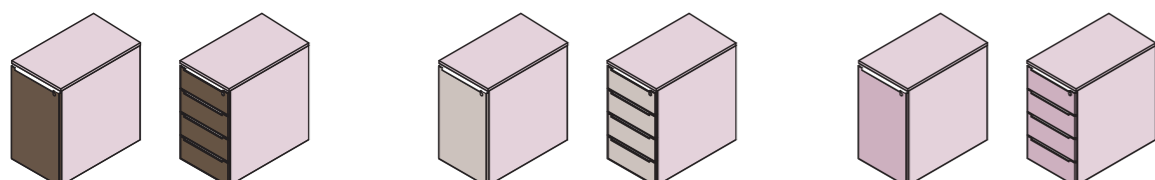

Variazioni su frontali con struttura e top laccati.  
 Variation of front elements with painted structure and top.  
 Variations des parties avant avec structure et plan de travail laqués.

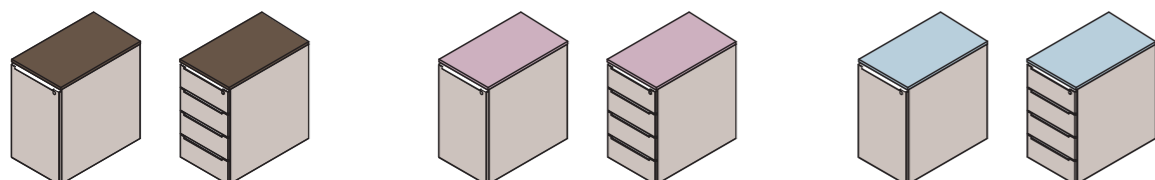

Variazioni su top con struttura e frontali in melaminico.  
 Variation of top with MFC structure and front elements.  
 Variations du plan de travail avec structure et parties avant en mélamine..

# MEDLEY

Mobile portante p80/ 60 cm  
 Supporting container d80/ 60cm  
 Meuble portant p80/60 cm

Nella pagina sinistra: tavola sinottica con alcuni possibili esempi di variazioni finitura. In questa pagina: disegno con riferimenti esplicativi per la disponibilità finitura/ colore per elemento.  
 A= struttura, B= frontali, C= top.

On the left: overview table with some examples of possible variations of finishes. On this page: drawing with explanation reference of availability finish/ color for item.  
 A= structure, B= front elements, C= top.

Dans la page de gauche : tableau synoptique avec quelques exemples de variations des finition. Dans cette page : dessin avec des références explicatives sur la disponibilité finition/couleur de l'objet.  
 A=structure, B=parties avant, C= plan de travail.

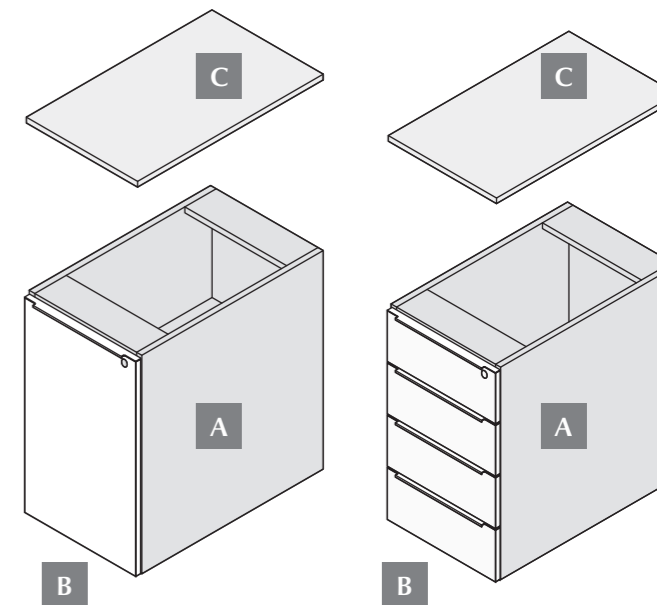

<b>A</b>	FINITURE MELAMINICO MFC FINISHES FINITION EN MELAMINE						
<b>B C</b>	FINITURE MELAMINICO MFC FINISHES FINITION EN MELAMINE						
<b>A B C</b>	FINITURE LACCATO OPACO OPAQUE PAINTED FINISHES FINITION LAQUES OPAQUES						
<b>C</b>	FINITURE VETRO GLASS FINISHES FINITION EN VERRE						

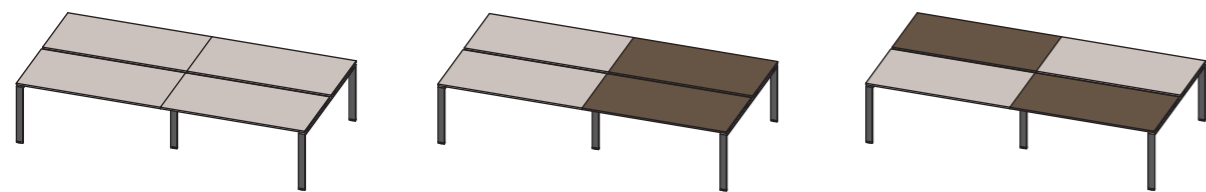

Variazioni sui piani lineari in melaminico.  
Variation of straight MFC desk tops.  
Variations des plans linéaires en mélamine.

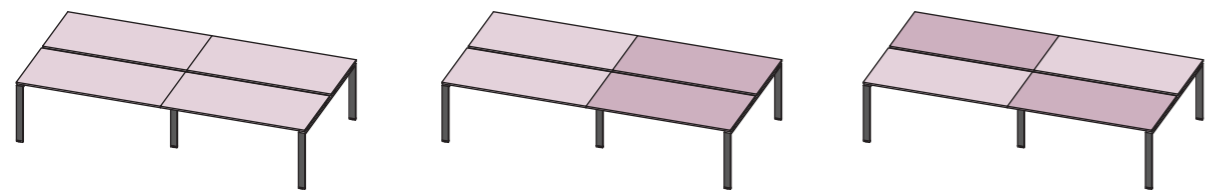

Variazioni sui piani lineari in laccato.  
Variation of straight painted desk tops.  
Variations des plans linéaires laqués.

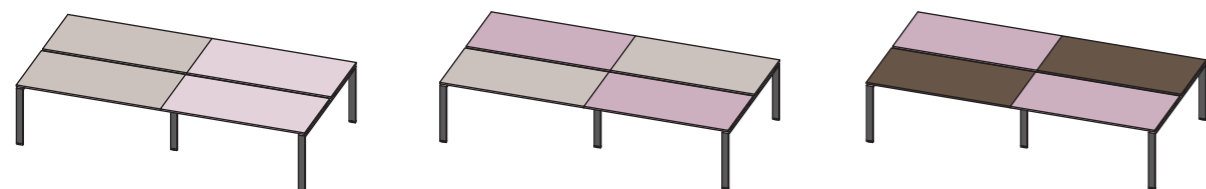

Variazioni sui piani lineari in melaminico e laccato.  
Variation of straight straight MFC and painted desk tops.  
Variations des plans linéaires laqués et en mélamine.

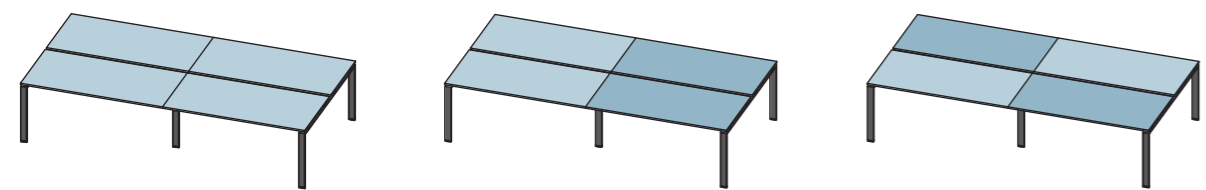

Variazioni sui piani lineari in vetro.  
Variation of straight glass desk tops.  
Variations des plans linéaires en verre.

# MEDLEY

Piani lineari e gamba "U" metallo  
Straight desk tops and metal "U" leg  
Plans linéaires et pied « U » en métal

Nella pagina sinistra: tavola sinottica con alcuni possibili esempi di variazioni finitura. In questa pagina: disegno con riferimenti esplicativi per la disponibilità finitura/ colore per elemento.  
A= piano lavoro, B= struttura

On the left: overview table with some examples of possible variations of finishes. On this page: drawing with explanation reference of availability finish/ color for item. A= desk top, B= structure

Dans la page de gauche : tableau synoptique avec quelques exemples de variations des finitions. Dans cette page : un dessin avec des références explicatives sur la disponibilité finition/couleur de l'objet. A= plan de travail, B= structure

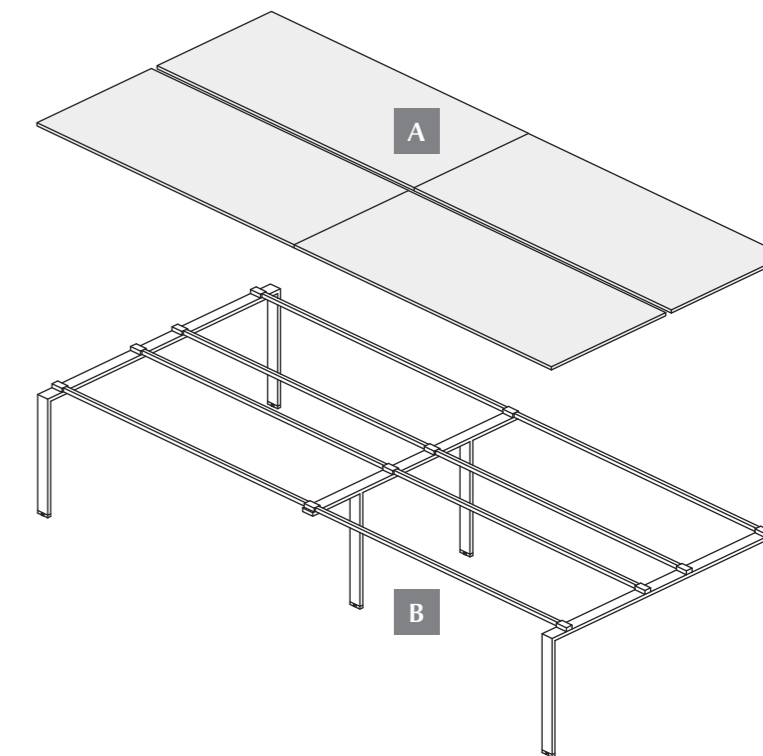

A	A	NIBC	NINN	NIAS	NICT	N2NO	N2WE	N2GT
FINITURE MELAMINICO MFC FINISHES FINITION EN MELAMINE		N2RO	N3RF	N3RT	N3CB	N3NS	N3LG	
A	A	L_TS	L_MC	L_CL	L_RC	L_AC	L_AB	L_SD
FINITURE LACCATO OPACO OPAQUE PAINTED FINISHES FINITION LAQUÉS OPAQUES		L_VA	L_BV	L_GS	L_CR	____ral		
A	A	EICT	VICL	EIBC	EIVA	VINE	VIBV	____ral
FINITURE VETRO GLASS FINISHES FINITION EN VERRE		M1BC	M1CT	M1AH	M1NE	M2AG	M3CF	M3OP
B	FINITURE METALLO METAL FINISHES FINITION EN METAL	M3MP	M3GW	M3AG	____ral			



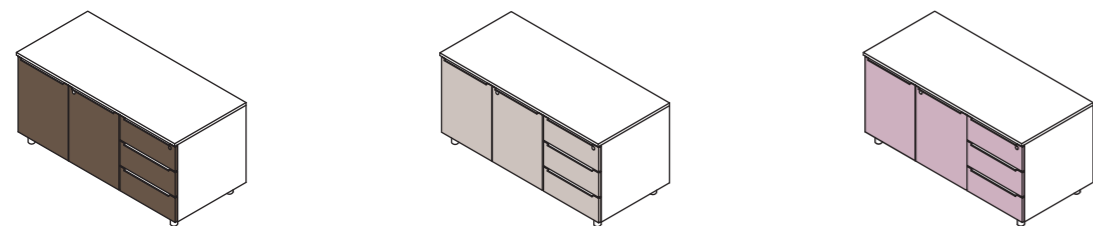

Variazioni su frontali con struttura in NIBC.  
Variation of front elements with structure in NIBC.  
Variations des parties avant avec structure NIBC.

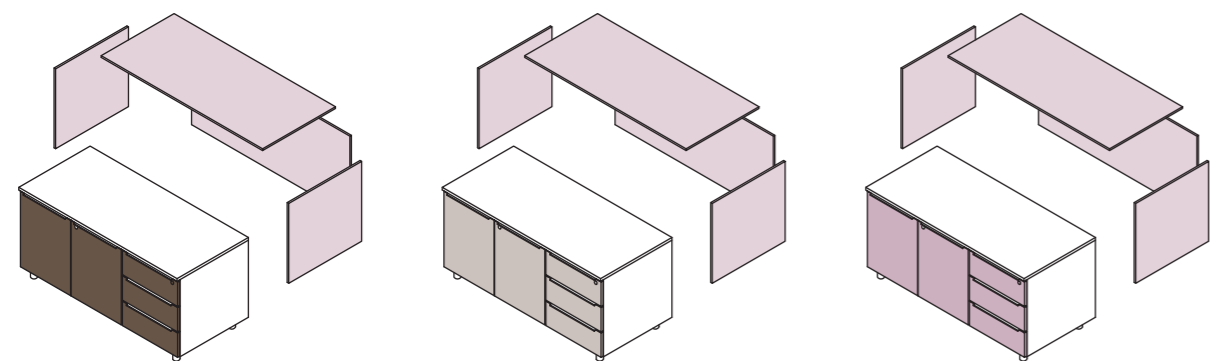

Variazioni su frontali con top, fianchi e schiena laccati.  
Variation of front elements with painted top, sides and rear panel.  
Variations des parties avant avec plan de travail, côtés et fond laqués.

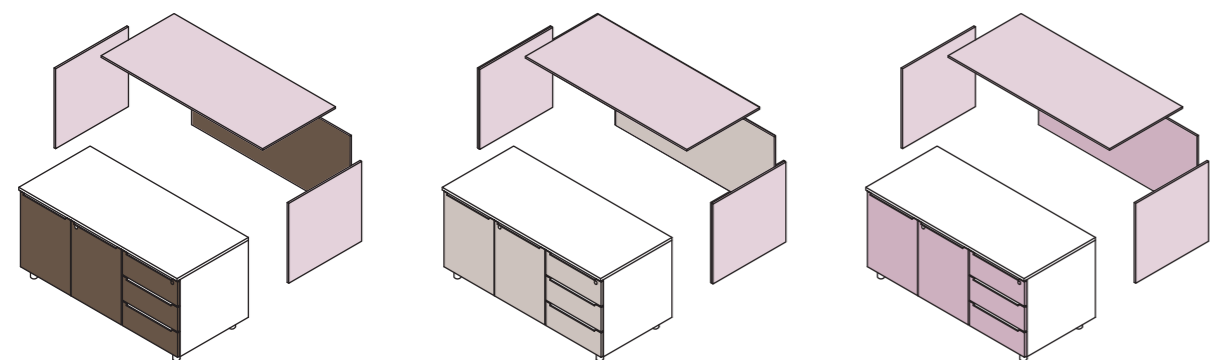

Variazioni su frontali e schiena con top e fianchi laccati.  
Variation of front elements and rear panel with painted top and side panels.  
Variations des parties avant et du fond avec plan de travail et laqués.

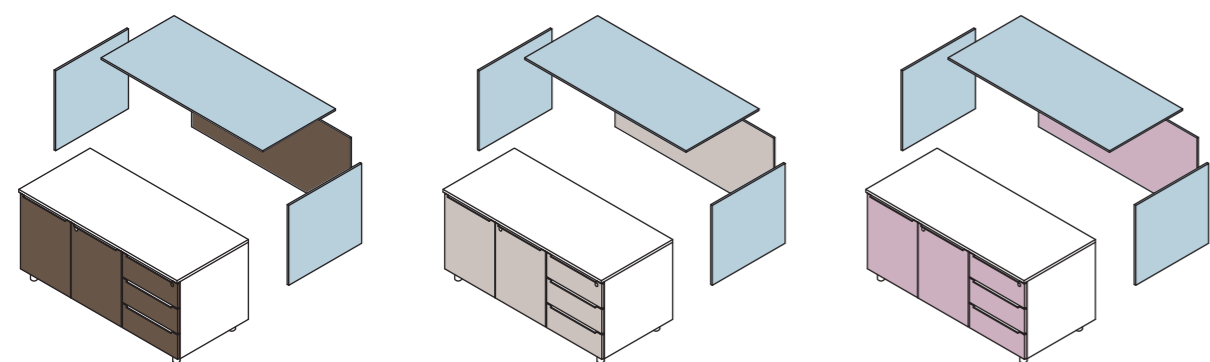

Variazioni su frontali e schiena con top e fianchi in vetro.  
Variation of front elements and rear panel with top and side panels in glass.  
Variations des parties avant et du fond avec plan de travail et côtés en verre.

# MEDLEY

Mobile di servizio  
Service unit  
Meuble de service

Nella pagina sinistra: tavola sinottica con alcuni possibili esempi di variazioni finitura. In questa pagina: disegno con riferimenti esplicativi per la disponibilità finitura/ colore per elemento.  
A= struttura, B= frontali, C= top e fianchi, D= schienale.

On the left: overview table with some examples of possible variations of finishes. On this page: drawing with explanation reference of availability finish/ color for item. A= structure, B= front elements, C= top and side panels, D= rear panel.

Dans la page de gauche : tableau synoptique avec quelques exemples de variations des finitions. Dans cette page : dessin avec des références explicatives sur la disponibilité finition/couleur de l'objet. A= structure, B= parties avant, C= plan de travail et côtés, D= fond.

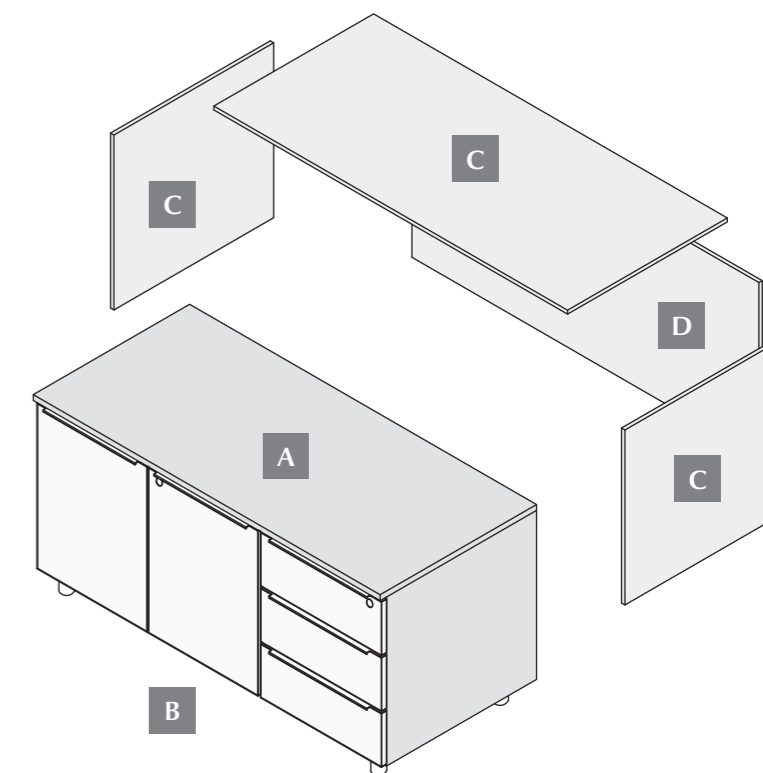

A FINITURE MELAMINICO  
MFC FINISHES  
FINITION EN MELAMINE

B|D B|D

FINITURE MELAMINICO  
MFC FINISHES  
FINITION EN MELAMINE

B|C|D B|C|D

FINITURE LACCATO OPACO  
OPAQUE PAINTED FINISHES  
FINITION LAQUES OPAQUES

C C

FINITURE VETRO  
GLASS FINISHES  
FINITION EN VERRE

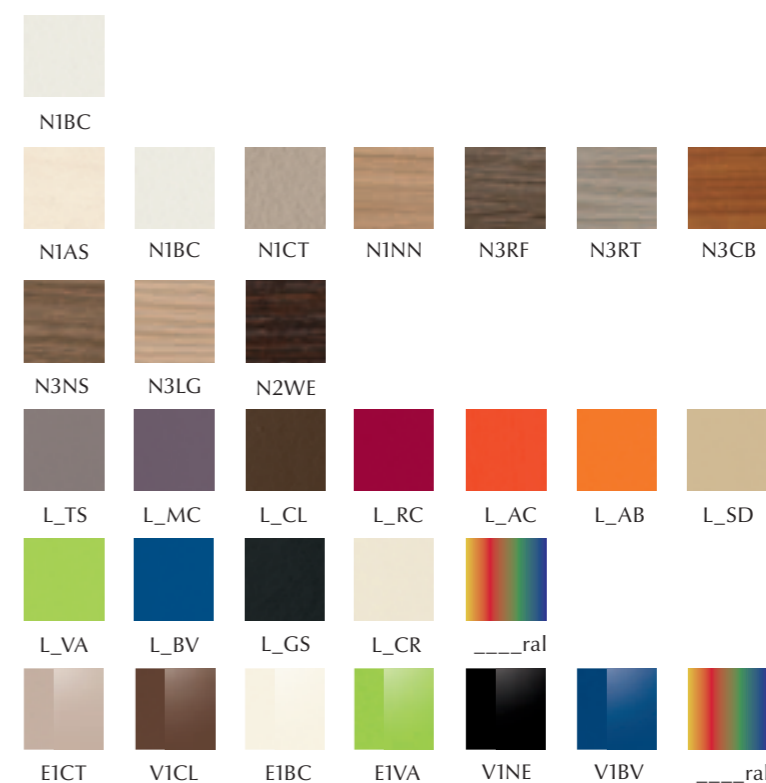

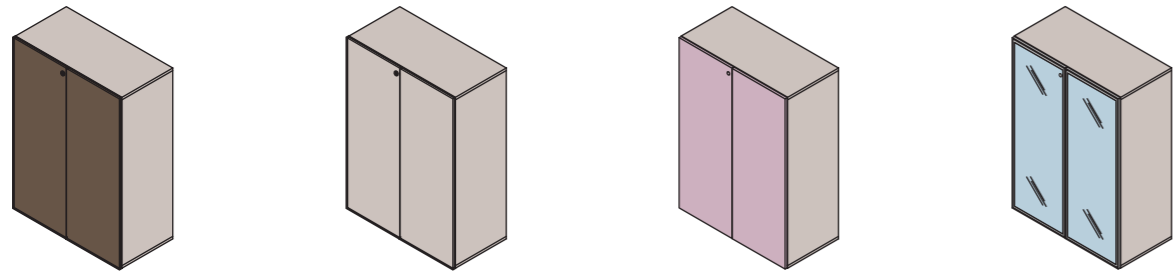

Variazioni su frontali con struttura melaminico (senza top e fianchi finitura).  
Variation of front panels with MFC structure (without finishing top and sides).  
Variations des parties avant avec structure en mélamine (sans plan de travail et côtés finition).

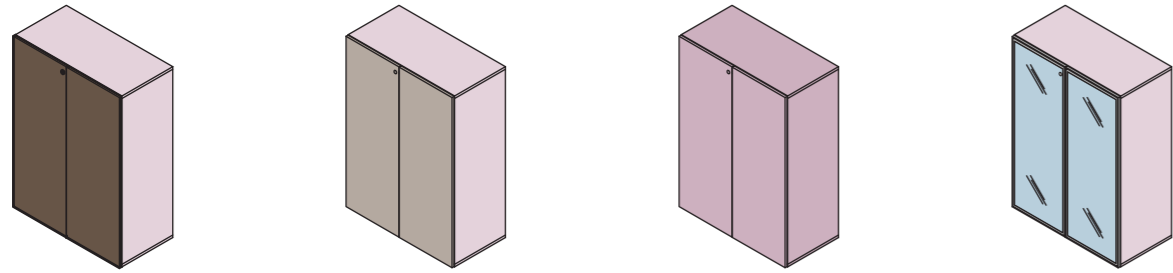

Variazioni su frontali con struttura laccata (senza top e fianchi finitura).  
Variation of front elements with painted structure (without finishing top and sides).  
Variations des parties avant avec structure laquée (sans plan de travail et côtés finition).

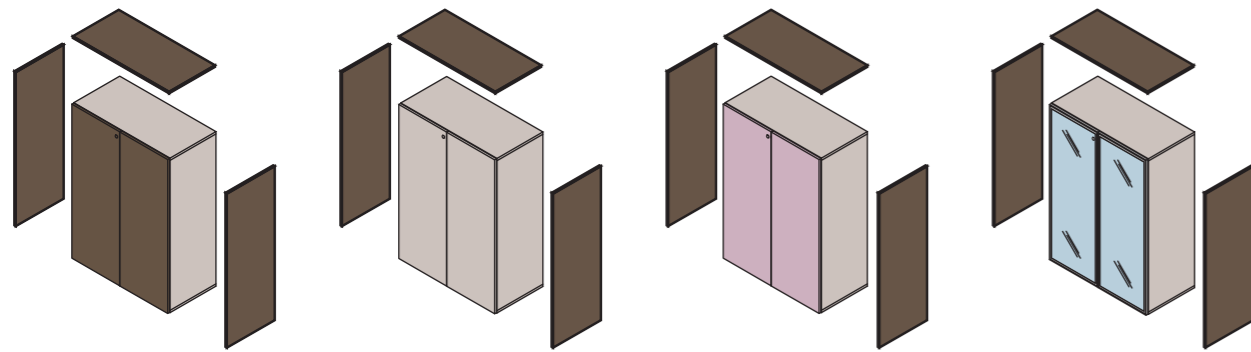

Variazioni su frontali con top e fianchi finitura in melaminico.  
Variation of front elements with MFC finishing top and sides.  
Variations des parties avant avec plan de travail et côtés, finition en mélamine.

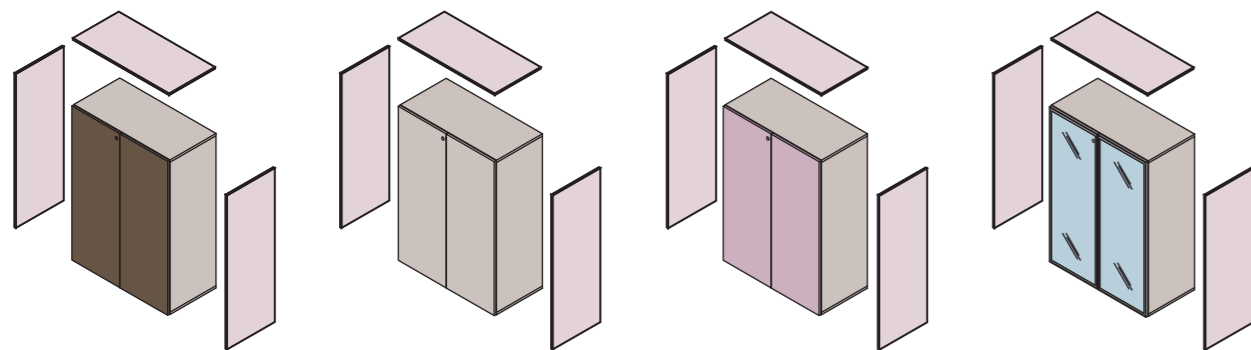

Variazioni su frontali con top e fianchi finitura laccati.  
Variation of front elements with painted finishing top and sides.  
Variations des parties avant avec plan de travail et côtés, finition laquée.

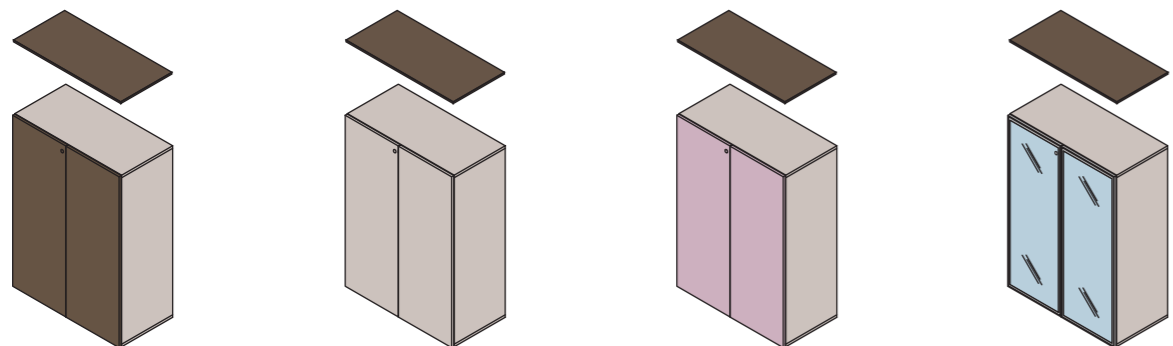

Variazioni su frontali con struttura in melaminico, con solo top di finitura.  
Variation of front elements with MFC structure, with finishing top only.  
Variations des parties avant, structure en mélamine avec seulement le plan de travail de finition.

# MEDLEY

Contenitori ad ante  
Modular shelving unit with doors  
Caissons avec portes

Nella pagina sinistra: tavola sinottica con alcuni possibili esempi di variazioni finitura. In questa pagina: disegno con riferimenti esplicativi per la disponibilità finitura/ colore per elemento.

A= struttura, B= frontali, C= top e fianchi.

On the left: overview table with some examples of possible variations of finishes. On this page: drawing with explanation reference of availability finish/ color for item. A= structure, B= front elements, C= top and side panels.

Dans la page de gauche : tableau synoptique avec quelques exemples de variations des finitions. Dans cette page : dessin avec des références explicatives sur la disponibilité finition/couleur de l'objet. A= structure, B= parties avant, C= plan de travail et côtés.

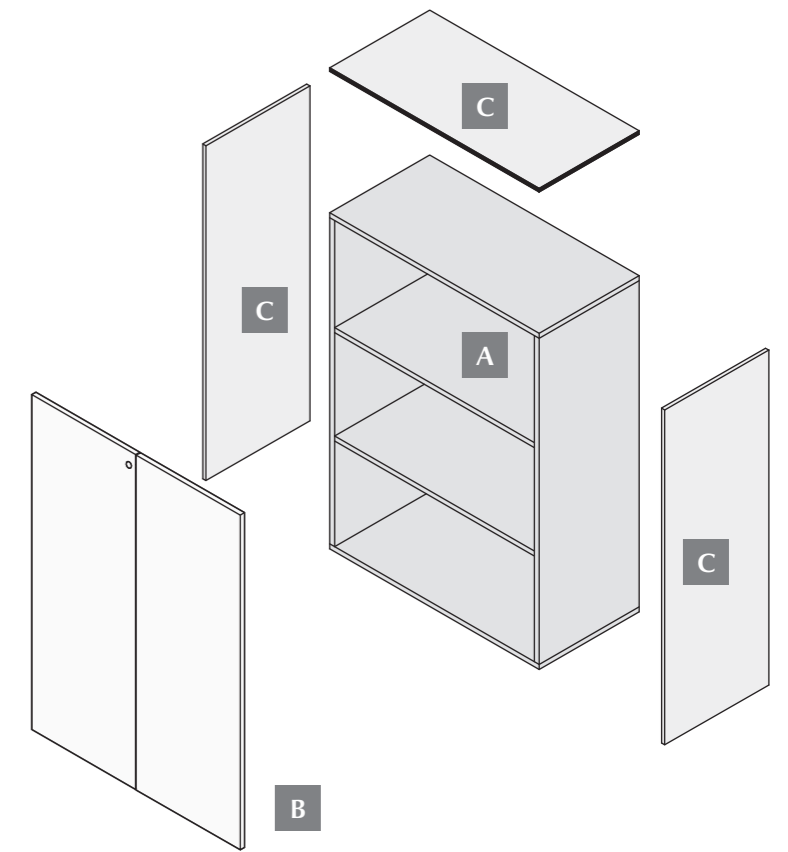

A FINITURE MELAMINICO  
MFC FINISHES  
FINITION EN MELAMINE



B|C FINITURE MELAMINICO  
MFC FINISHES  
FINITION EN MELAMINE



B FINITURE MELAMINICO  
MFC FINISHES  
FINITION EN MELAMINE

A|B|C FINITURE LACCATO OPAO  
OPAQUE PAINTED FINISHES  
FINITION LAQUES OPAQUES



B FINITURE VETRO  
GLASS FINISHES  
FINITION EN VERRE

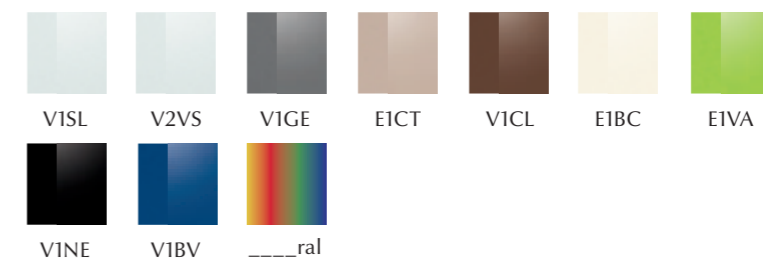



# MEDLEY

Pentagramma abbinamenti piani e strutture  
*Stave of matching work tops and structures*  
*Portée assortiment de plans et structures*

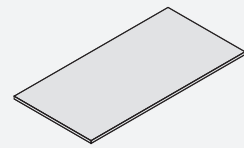

Piano p900/sp30mm  
 Desk top d900/th30mm  
 Plan p900/ép30mm

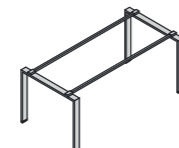

Gamba U US p900mm  
 U Leg US d900mm  
 Pied U US p900mm

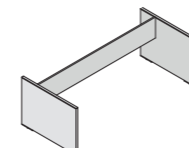

Struttura sp30/ p900 mm  
 Structure th30/ d900mm  
 Structure ép30/p900 mm

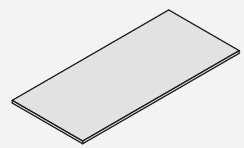

Piano p900/sp18mm  
 Desk top d900/th18mm  
 Plan p900/ép18mm

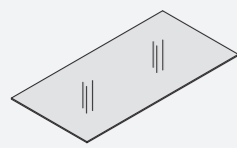

Piano p900/sp10mm  
 Desk top d900/th10mm  
 Plan p900/ép10mm

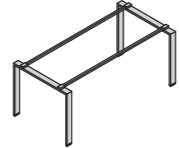

Gamba U US p900mm  
 U Leg US d900mm  
 Pied U US p900mm

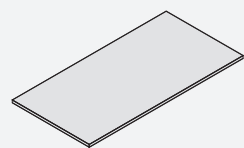

Piano p600/800/sp30mm  
 Desk top d600/800/th30mm  
 Plan p600/800/ép30mm

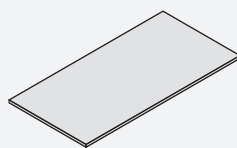

Piano p600/800/sp25mm  
 Desk top d600/800/th25mm  
 Plan p600/800/ép25mm

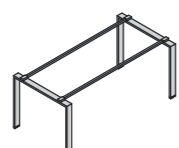

Gamba U US p600/800mm  
 U Leg US d600/800mm  
 Pied U US p600/800mm

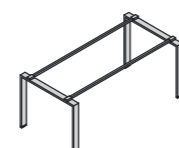

Gamba U MEDLEY p600/800mm  
 U Leg MEDLEY d600/800mm  
 Pied U MEDLEY p600/800mm

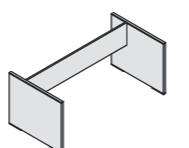

Struttura sp30/p800mm  
 Structure th30/d800mm  
 Structure ép30/p800mm

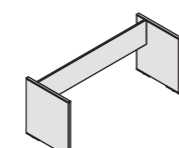

Struttura sp30/p600mm  
 Structure th30/d600mm  
 Structure ép30/p600mm

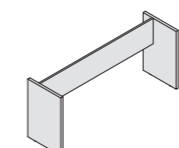

Struttura melaminico con  
 2 mezzi fianchi sp30/  
 p450mm  
 Structure MFC with  
 2 short sides th30/d450mm  
 Structure en mélamine avec  
 2 demi côtés ép30/p450mm

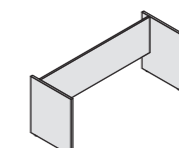

Struttura sp25/ p570 mm  
 Structure th25/570mm  
 Structure ép25/p570mm

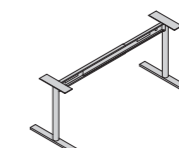

Gamba T US p600/800mm  
 T Leg US d600/800mm  
 Pied T US p600/800mm

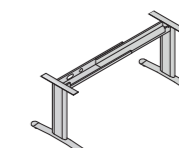

Gamba T FUNNY p600/800mm  
 T Leg FUNNY d600/800mm  
 Pied T FUNNY p600/800mm

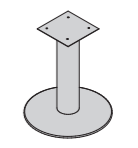

Colonna base tonda ø550mm  
 Round metal column base  
 ø550mm  
 Colonne base ronde ø550mm

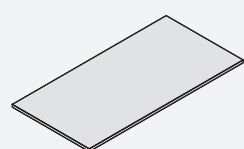

Piano p600/800/sp18mm  
 Desk top d600/800/th18mm  
 Plan p600/800/ép18mm

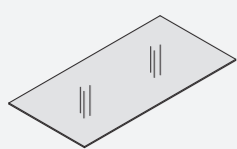

Piano p600/800/sp10mm  
 Desk top d600/800/th10mm  
 Plan p600/800/ép10mm

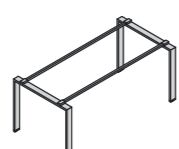

Gamba U US p600/800mm  
 U Leg US d600/800mm  
 Pied U US p600/800mm

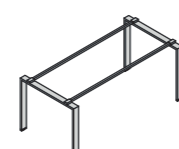

Gamba U MEDLEY p600/800mm  
 U Leg MEDLEY d600/800mm  
 Pied U MEDLEY p600/800mm

Un pentagramma per scegliere le note che meglio si accordano alle vostre esigenze.

Piani di diversi spessori, da combinare nelle strutture più varie.

Nel listino tecnico tutte le indicazioni in dettaglio.

*A stave to choose the notes that best fit your needs.*

*Desk tops of different thicknesses, to be combined with various structures.*

*In the technical price list all the technical information in detail.*

*Une portée pour choisir les notes qui s'accordent au mieux à vos exigences.*

*Plans de travail de différentes épaisseurs qui peuvent se composer de différentes structures.*

*Dans le catalogue vous trouverez toutes les indications détaillées.*

Piani lavoro sp30 mm /Desk top th30mm / Plan de travail ép30 mm

# MEDLEY

Piani lavoro melaminico sp 30mm e sp 25mm  
MFC desk top th 30mm and th 25mm  
Plan de travail en mélamine ép 30mm et ép 25mm

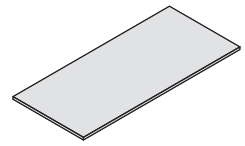

Piano lineare p900 mm  
Straight desk top d900mm  
Plan de travail linéaire p900 mm

FINITURE MELAMINICO  
MFC FINISHES  
FINITION EN MELAMINE



FINITURE LACCATO OPACO  
OPAQUE PAINTED FINISHES  
FINITION LAQUES OPAQUES

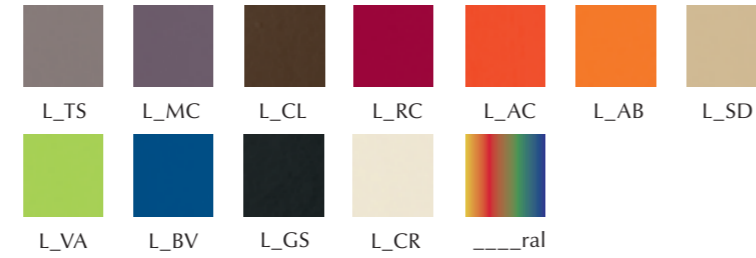

Piani lavoro sp30 mm /Desk top th30mm / Plan de travail ép30 mm

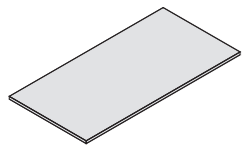

Piano lineare p600/ 800 mm  
Straight desk top d600/ 800mm  
Plan de travail linéaire p600/ 800 mm

FINITURE MELAMINICO  
MFC FINISHES  
FINITION EN MELAMINE



FINITURE LACCATO OPACO  
OPAQUE PAINTED FINISHES  
FINITION LAQUES OPAQUES

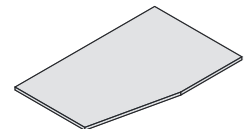
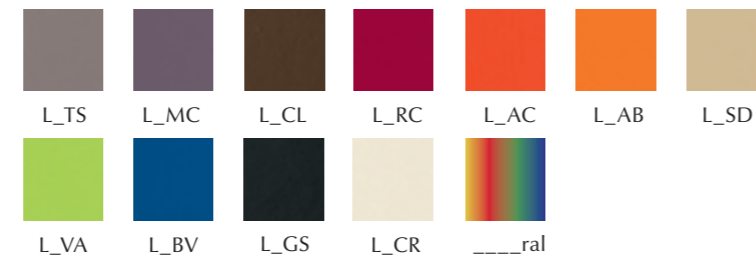

Piano sagomato p800/ 1000 mm  
Shaped desk top d800/ 1000mm  
Plan galbé p800/1000 mm

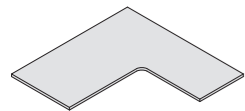

Piano compatto p800/ 600 mm  
Corner desk top d800/ 600mm  
Plan compact p800/600 mm

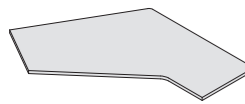
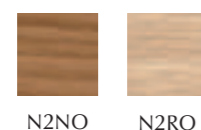

Piano compatto 120°  
Crescent desk top 120°  
Plan compact 120°

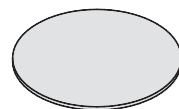
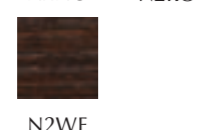

Piano circolare ø1200 mm  
Round desk top ø1200mm  
Plan circulaire ø 1200 mm

Piani lavoro sp25 mm /Desk top th25mm / Plan de travail ép25 mm

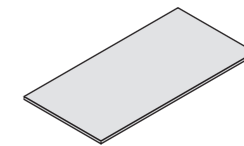

Piano lineare p600/ p800 mm  
Straight desk top d600/ d800mm  
Plan linéaire p600/p800 mm

FINITURE MELAMINICO  
MFC FINISHES  
FINITION EN MELAMINE



FINITURE LACCATO OPACO  
OPAQUE PAINTED FINISHES  
FINITION LAQUES OPAQUES

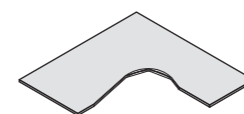

Piano compatto p800/ 600 mm  
Corner desk top d800/ 600mm  
Plan compact p800/600 mm

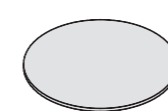
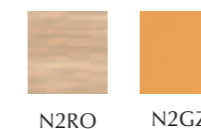

Piano circolare ø1050 mm  
Round desk top ø1050mm  
Plan circulaire ø 1050 mm



# MEDLEY

Piani lavoro melaminico sp18mm e vetro sp10mm  
 Desk tops MFC th18mm and glass th10mm  
 Plan de travail en mélamine ép18mm et verre ép10mm

Piani lavoro sp18mm / Desk tops th18mm / Plan de travail ép18mm

Piani lavoro sp10mm / Desk tops th10mm / Plan de travail ép10mm

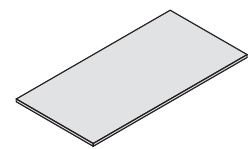

Piano lineare p900 mm  
 Straight desk top d900mm  
 Plan de travail linéaire p900 mm

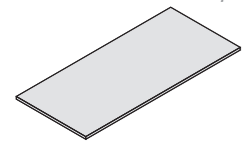

Piano lineare p600/ 800 mm  
 Straight desk top d600/800mm  
 Plan linéaire p600/800 mm

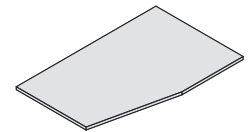

Piano sagomato p800/ 1000 mm  
 Straight desk top d800/1000mm  
 Plan galbé p800/1000 mm

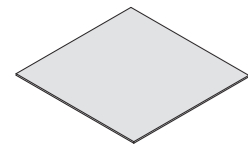

Piano unico L1600/ p1640 mm  
 One piece desk top L1600/ d1640mm  
 Plan unique L1600/p1640 mm

FINITURE MELAMINICO  
 MFC FINISHES  
 FINITION EN MELAMINE

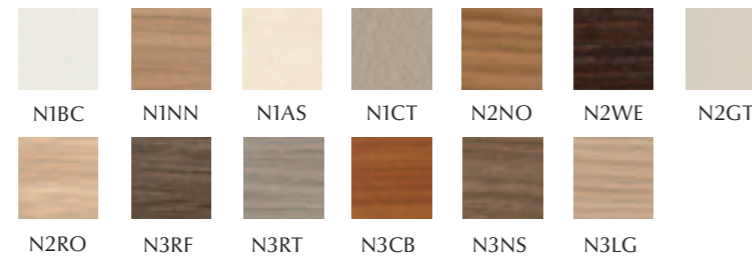

FINITURE LACCATO OPACO  
 OPAQUE PAINTED FINISHES  
 FINITION LAQUES OPAQUES

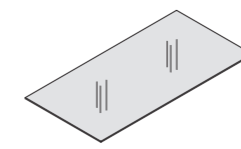
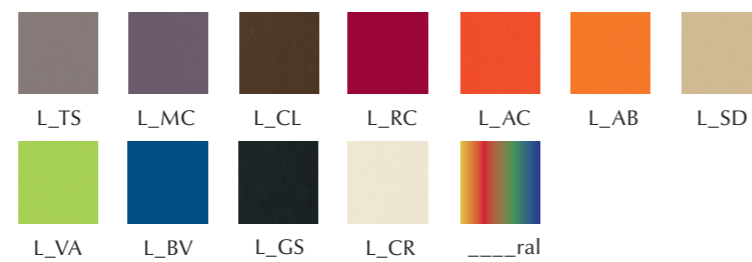

Piano lineare p900 mm  
 Straight desk top d900mm  
 Plan linéaire p900 mm

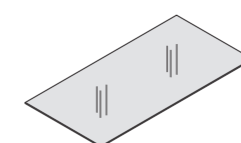

Piano lineare p600/ 800 mm  
 Straight desk top d600/800mm  
 Plan linéaire p600/800 mm

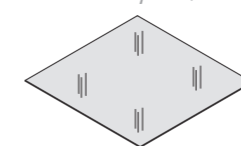

Piano unico L1600/ p1640 mm  
 One piece desk top L1600/ d1640mm  
 Plan unique L1600/p1640 mm

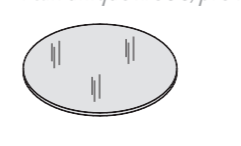

Piano circolare ø1050 mm  
 Round desk top ø1050mm  
 Plan circulaire ø1050 mm

FINITURE VETRO  
 GLASS FINISHES  
 FINITION EN VERRE



# MEDLEY

Strutture melaminico sp30mm e sp25mm  
*Structure MFC th30mm and th25mm*  
*Structure en mélamine ép30mm et ép25mm*

## Strutture sp30mm / *Structure th30mm* / *Structure ép30mm*

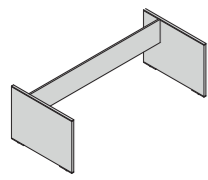

Struttura melaminico sp30/ p900 mm  
*Structure MFC th30/ d900mm*  
*Structure en mélamine ép30/p900 mm*

FINITURE MELAMINICO  
*MFC FINISHES*  
*FINITION EN MELAMINE*



FINITURE LACCATO OPACO  
*OPAQUE PAINTED FINISHES*  
*FINITION LAQUES OPAQUES*

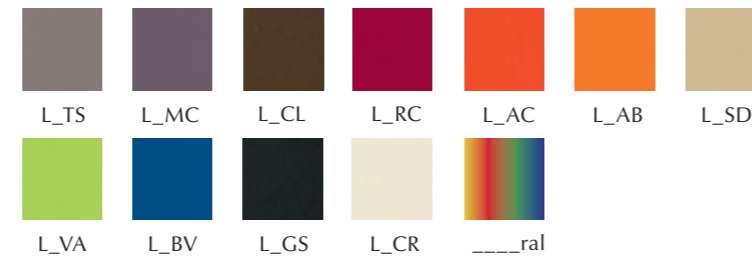

## Strutture sp30mm / *Structure th30mm* / *Structure ép30mm*

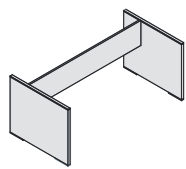

Struttura melaminico sp30/p800mm  
*Structure MFC th30/d800mm*  
*Structure en mélamine ép30/p800mm*

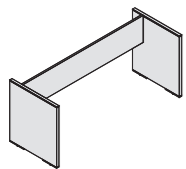

Struttura melaminico sp30/p600mm  
*Structure MFC th30/d600mm*  
*Structure en mélamine ép30/p600mm*

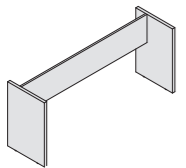

Struttura melaminico con  
 2 mezzi fianchi sp30/p450mm  
*Structure MFC with*  
*2 short sides th30/d450mm*  
*Structure en mélamine avec*  
*2 demi côtés ép30/p450mm*

FINITURE MELAMINICO  
*MFC FINISHES*  
*FINITION EN MELAMINE*



FINITURE LACCATO OPACO  
*OPAQUE PAINTED FINISHES*  
*FINITION LAQUES OPAQUES*



## Strutture sp25mm / *Structure th25mm* / *Structure ép25mm*

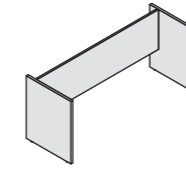

Struttura melaminico sp25/ p570 mm  
*Structure MFC th25/ d570mm*  
*Structure en mélamine ép25/p570 mm*

FINITURE MELAMINICO  
*MFC FINISHES*  
*FINITION EN MELAMINE*



FINITURE LACCATO OPACO  
*OPAQUE PAINTED FINISHES*  
*FINITION LAQUES OPAQUES*



# MEDLEY

Strutture metallo FUNNY - US - MEDLEY  
 Metal structures FUNNY - US - MEDLEY  
 Structure en métal FUNNY - US - MEDLEY

## Strutture FUNNY/ FUNNY Structures / Structure FUNNY

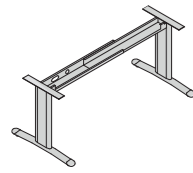

Struttura metallo gamba T FUNNY  
 p600/800mm  
 Metal structure FUNNY T-leg  
 d600/800mm  
 Structure en métal pied T FUNNY  
 p600/800mm

FINITURE METALLO  
 METAL FINISHES  
 FINITION EN METAL



M2AG

FINITURE METALLO VERNICIATI MEDLEY E RAL  
 FINISHES METAL PAINTINGS MEDLEY AND RAL  
 FINITIONS EN MÉTAL ET VERNIS MEDLEY ET RAL

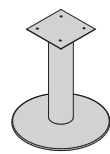
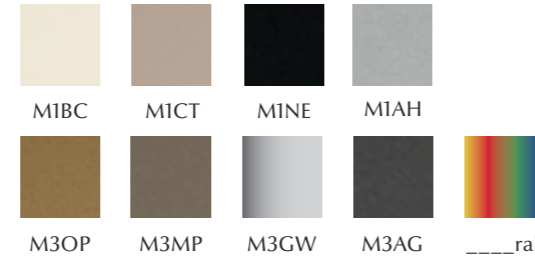

Struttura metallo colonna su base tonda  
 ø550mm  
 Metal column structure on round base  
 ø550mm  
 Structure en métal colonne avec base ronde  
 ø550mm

FINITURE METALLO  
 METAL FINISHES  
 FINITION EN METAL



M2AG M3CF

FINITURE METALLO VERNICIATI MEDLEY E RAL  
 FINISHES METAL PAINTINGS MEDLEY AND RAL  
 FINITIONS EN MÉTAL ET VERNIS MEDLEY ET RAL

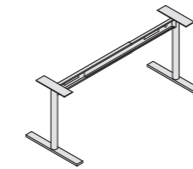
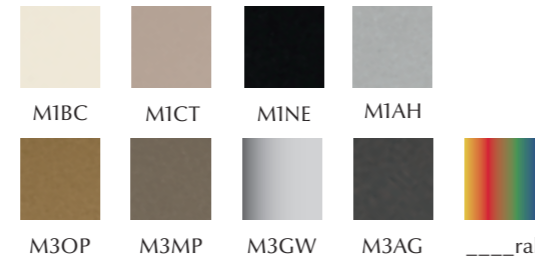

Struttura metallo gamba a T US  
 p600/800mm  
 Metal structure US T-leg  
 d600/800mm  
 Structure en métal pied T US  
 p600/800mm

FINITURE METALLO  
 METAL FINISHES  
 FINITION EN METAL



MIBC MICT



MIAH M3CF

FINITURE METALLO VERNICIATI MEDLEY E RAL  
 FINISHES METAL PAINTINGS MEDLEY AND RAL  
 FINITIONS EN MÉTAL ET VERNIS MEDLEY ET RAL



MINE M3OP M3MP M3GW M3AG \_\_\_\_ral

## Strutture MEDLEY/ MEDLEY Structures / Structure MEDLEY

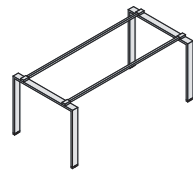

Struttura metallo gamba a U MEDLEY  
 p600/800mm  
 Metal structure MEDLEY U-leg  
 d600/800mm  
 Structure en métal pied U MEDLEY  
 p600/800mm

FINITURE METALLO  
 METAL FINISHES  
 FINITION EN METAL



M2AG

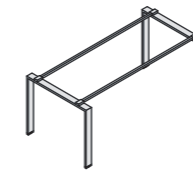

Struttura metallo gamba U US  
 p600/800/900mm  
 Metal structure US U-leg  
 d600/800/900mm  
 Structure en métal pied U US  
 p600/800/900mm

FINITURE METALLO  
 METAL FINISHES  
 FINITION EN METAL



MIBC MICT MINE



MIAH M3CF

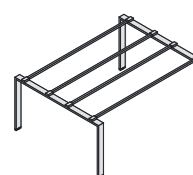

Struttura metallo gamba a U MEDLEY  
 p1240/1640mm  
 Metal structure MEDLEY U-leg  
 d1240/1640mm  
 Structure en métal pied U MEDLEY  
 p1240/1640mm

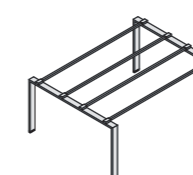

Struttura metallo gamba U US  
 p1240/1640mm  
 Metal structure US U-leg  
 d1240/1640mm  
 Structure en métal pied U US  
 p1240/1640mm

FINITURE METALLO VERNICIATI MEDLEY E RAL  
 FINISHES METAL PAINTINGS MEDLEY AND RAL  
 FINITIONS EN MÉTAL ET VERNIS MEDLEY ET RAL



M3OP M3MP M3GW M3AG \_\_\_\_ral





# MEDLEY

Libreria modulare con struttura in alluminio  
 Modular bookcase with aluminium structure.  
 Bibliothèque modulable avec structure en aluminium.

Nella pagina sinistra: tavola sinottica con alcuni possibili esempi di variazioni finitura. In questa pagina: disegno con riferimenti esplicativi per la disponibilità finitura/ colore per elemento.  
 A= ripiani, B= struttura ALU

On the left: overview table with some examples of possible variations of finishes. On this page: drawing with explanation reference of availability finish/ color for item.  
 A= shelves, B= aluminium structure

Dans la page de gauche : tableau synoptique avec quelques exemples de variations des finitions. Dans cette page : dessin avec des références explicatives sur la disponibilité finition/couleur de l'objet.  
 A= étagères, B= structure ALU

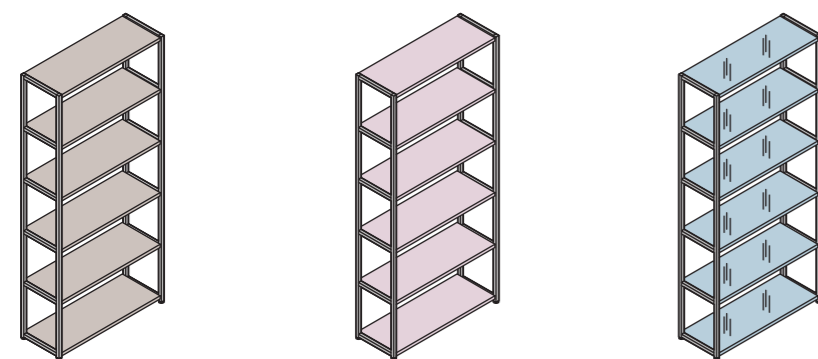
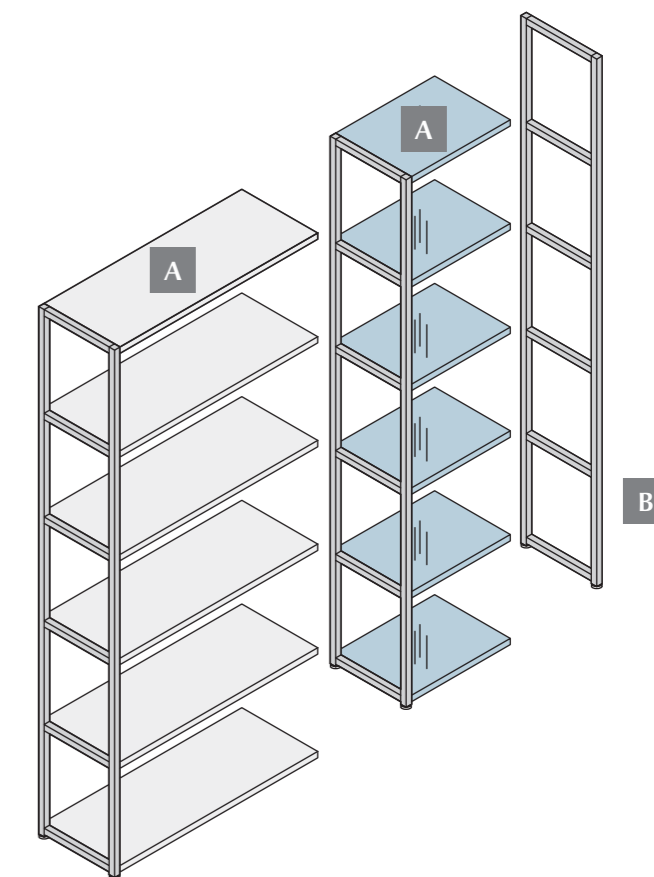

Variazioni sui ripiani.  
 Variation of shelves.  
 Variations des étagères.



FINITURE MELAMINICO  
 MFC FINISHES  
 FINITION EN MELAMINE



FINITURE LACCATO OPACO  
 OPAQUE PAINTED FINISHES  
 FINITION LAQUES OPAQUES

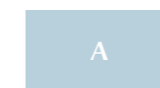

FINITURE VETRO  
 GLASS FINISHES  
 FINITION EN VERRE



FINITURE ALLUMINIO  
 ALUMINIUM FINISHING  
 FINITION EN ALUMINIUM



N3NJ N3BD



L\_TS L\_MC L\_CL L\_RC L\_AC L\_AB L\_SD L\_VA L\_BV L\_GS L\_CR \_\_\_\_ral



EICT VI CL EIBC EIVA VINE VIBV 9003ral \_\_\_\_ral



9003ral CIAA

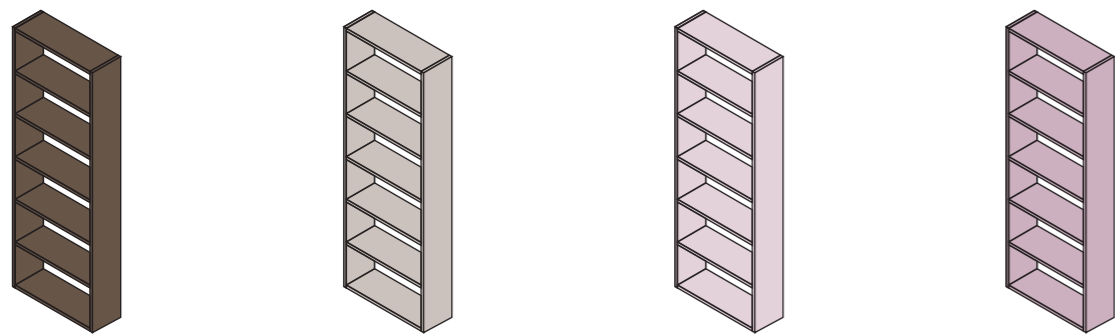

Variazioni sulla struttura in melaminico.  
Variation of MFC structure.  
Variations de la structure en mélamine.

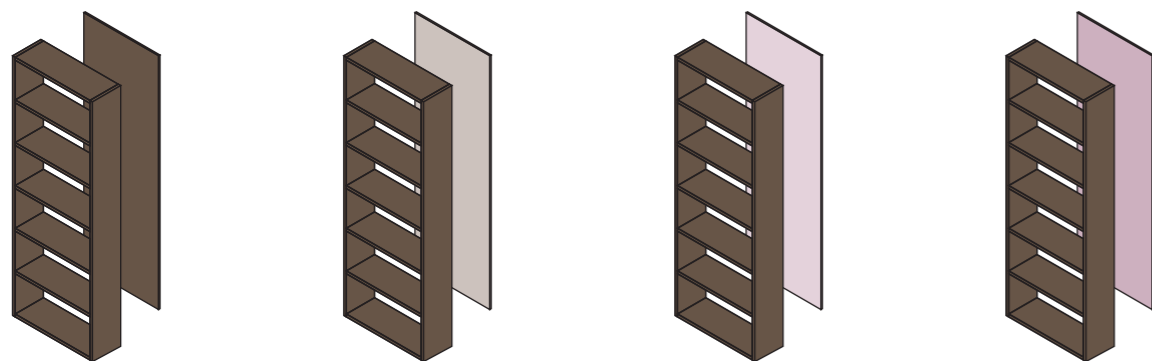

Variazioni sugli schienali sp12/ 18mm.  
Variation of rear panels th12/18mm.  
Variations des panneaux arrières ép12/18mm.

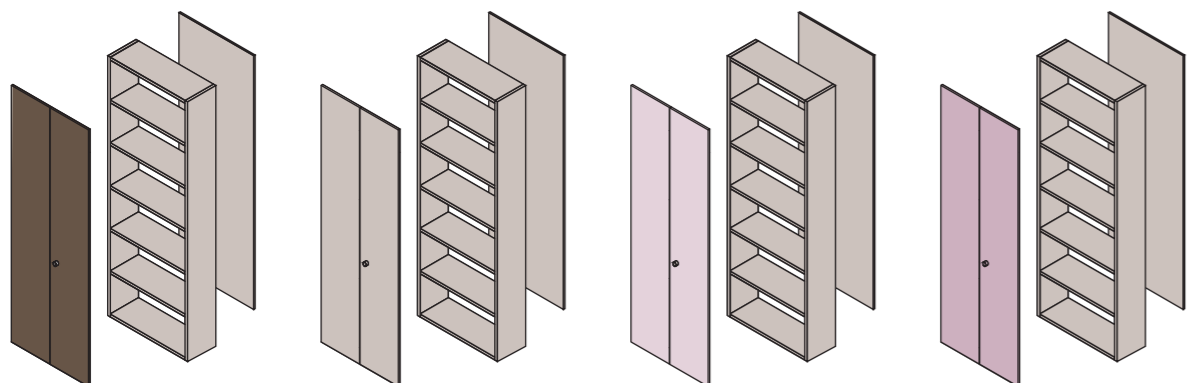

Variazioni sulle ante melaminico US.  
Variation of MFC US doors.  
Variations des portes en mélamine US.

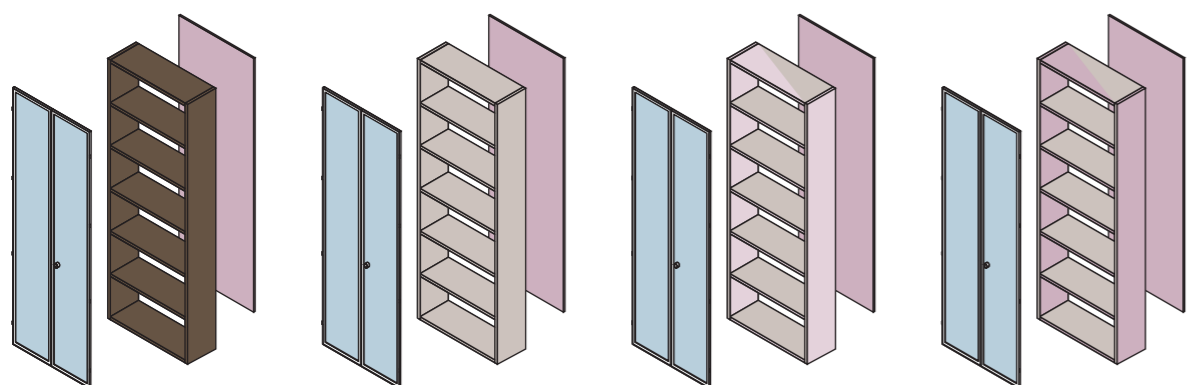

Variazioni sulla struttura in melaminico.  
Variation of MFC structure.  
Variations de la structure en mélamine.

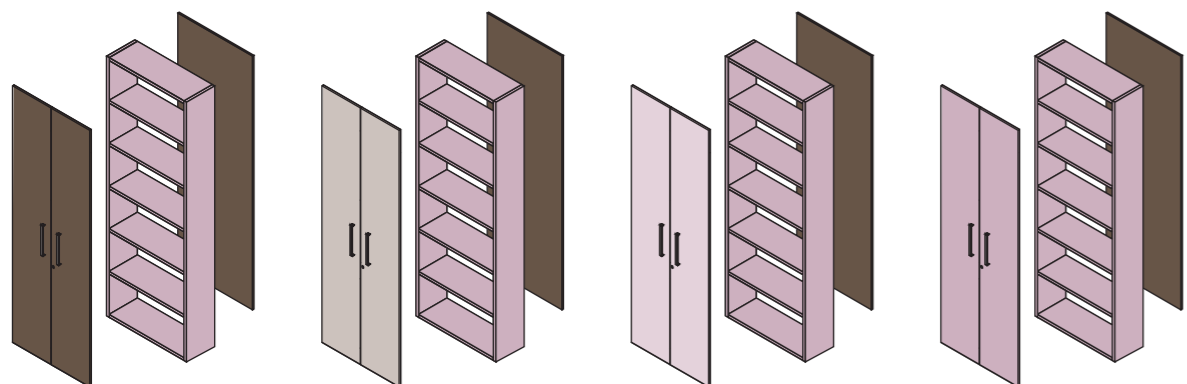

Variazioni sulle ante melaminico MEDLEY.  
Variation of MFC MEDLEY doors.  
Variations des portes en mélamine MEDLEY.

# MEDLEY

Libreria modulare p330mm  
Modular bookcase d330mm  
Bibliothèque modulaire p330mm

Nella pagina sinistra: tavola sinottica con alcuni possibili esempi di variazioni finitura. In questa pagina: disegno con riferimenti esplicativi per la disponibilità finitura/ colore per elemento.

A= struttura, B= frontali US, C= frontali MEDLEY, D= schienali 12mm, E= schienali 18mm

On the left: overview table with some examples of possible variations of finishes. On this page: drawing with explanation reference of availability finish/ color for item.

A= structure, B= US front elements, C= MEDLEY front elements D= rear panels 12mm, E= rear panels 18mm

Dans la page de gauche: tableau synoptique avec quelques exemples de variations des finitions. Dans cette page : dessin avec des références explicatives sur la disponibilité finition/ couleur de l'objet.

A= structure, B= parties avant US, C= parties avant MEDLEY, D= panneaux arrières 12mm, E= panneaux arrières 18mm

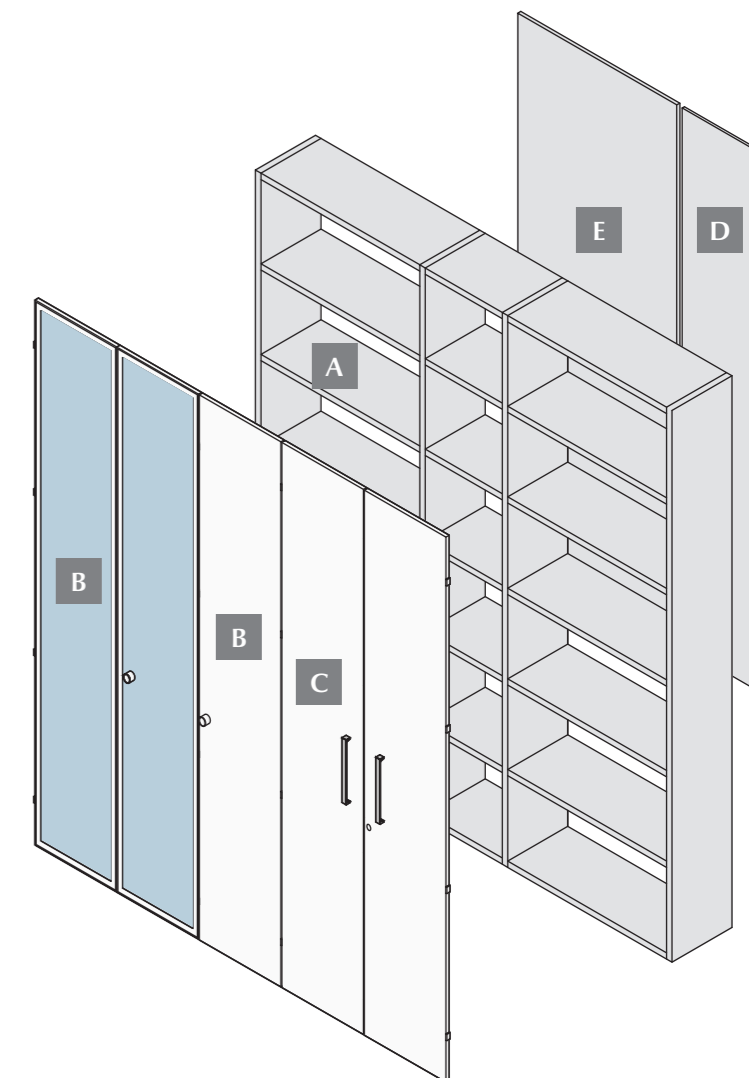

FINITURE MELAMINICO  
MFC FINISHES  
FINITION EN MELAMINE



NINN NIAS NICT NIBC



FINITURE MELAMINICO  
MFC FINISHES  
FINITION EN MELAMINE

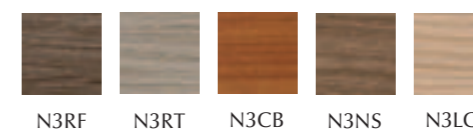

N3RF N3RT N3CB N3NS N3LG



FINITURE MELAMINICO  
MFC FINISHES  
FINITION EN MELAMINE



N1BF N1CA



FINITURE LACCATO OPACO  
OPAQUE PAINTED FINISHES  
FINITION LAQUES OPAQUES



L\_TS L\_MC L\_CL L\_RC L\_AC L\_AB L\_SD L\_VA L\_BV L\_GS L\_CR \_\_\_ral



FINITURE VETRO  
GLASS FINISHES  
FINITION EN VERRE

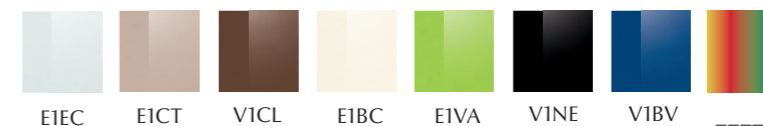

EIEC EICT VICL EIBC EIVA VINE VIBV \_\_\_ral

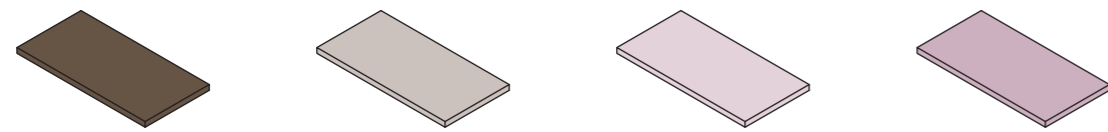

Variazioni su top inserto in melaminico.  
Variation of MFC insert top.  
Variations du plan de travail avec détail en mélamine.

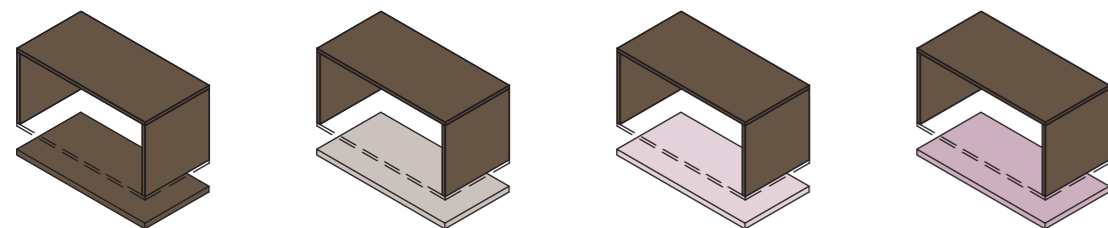

Variazioni su base sopralzo.  
Variation of base of open shelf.  
Variations de la base du caisson supérieur.

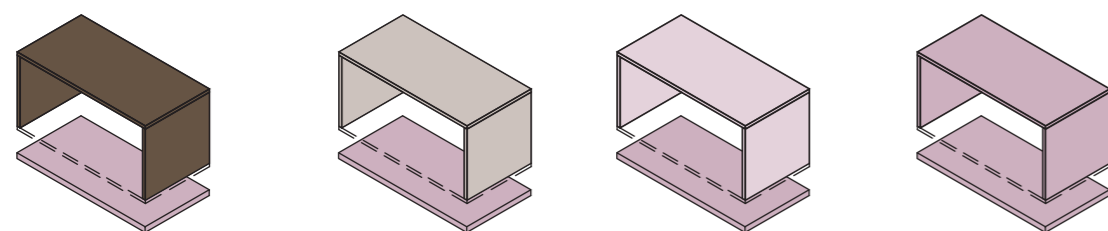

Variazioni su struttura sopralzo.  
Variation of structure of open shelf.  
Variations de la structure du caisson supérieur.

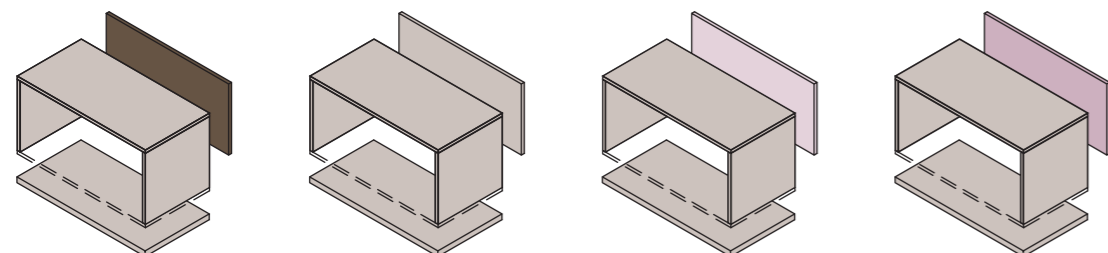

Variazioni su schienale sopralzo.  
Variation of rear panel of open shelf.  
Variations du fond du caisson supérieur.

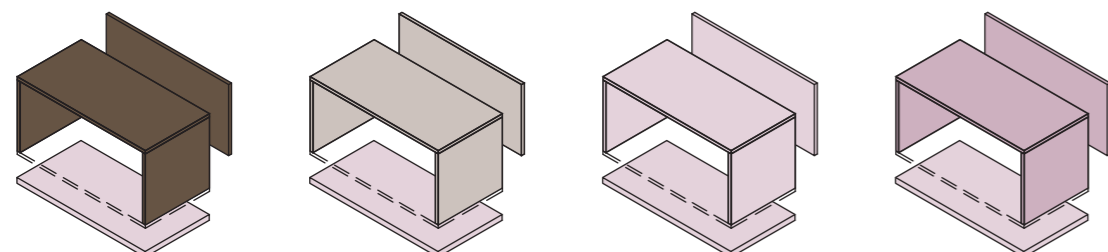

Variazioni su schienale e struttura sopralzo.  
Variation of rear panel and structure of open shelf.  
Variations du fond et de la structure du caisson supérieur.

# MEDLEY

Sopralzi e top inserto L600/800mm e p330/400mm  
Open shelves and insert tops L600/800mm and d330/400mm  
Caisson supérieur et détail plan de travail L600/800mm et p330/400mm

Nella pagina sinistra: tavola sinottica con alcuni possibili esempi di variazioni finitura. In questa pagina: disegno con riferimenti esplicativi per la disponibilità finitura/ colore per elemento.

A= struttura, B= base/top sp18mm, C= base/top sp25mm, D= base/ top sp30mm, E= schienale.

On the left: overview table with some examples of possible variations of finishes. On this page: drawing with explanation reference of availability finish/ color for item.  
A= structure, B= base/top th18mm, C= base/top th25mm, D= base/top th30mm, E= rear panel.

Dans la page de gauche : tableau synoptique avec quelques exemples de variations des finitions. Dans cette page : dessin avec des références explicatives sur la disponibilité finition/couleur de l'objet. A= structure, B= base/plan de travail ép18mm, C=base/plan de travail ép25mm, D= base/plan de travail ép30mm, E=fond.

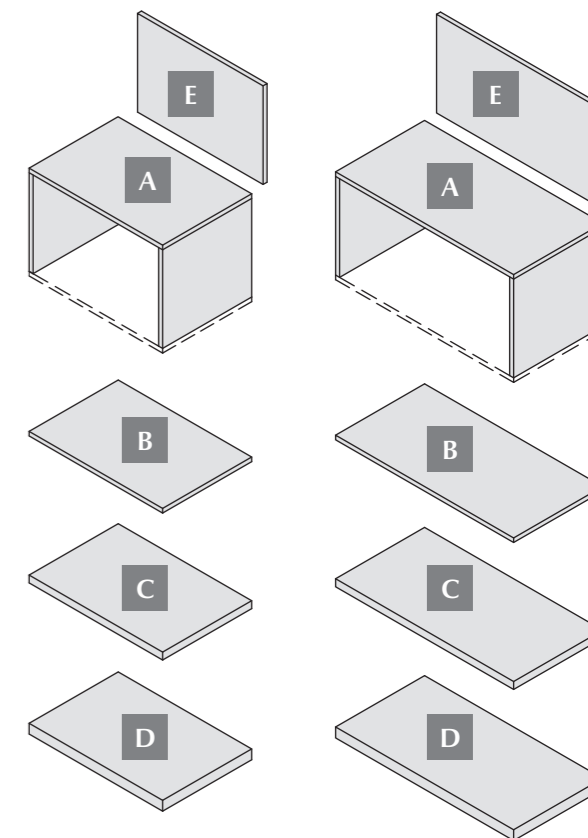

FINITURE MELAMINICO  
MFC FINISHES  
FINITION EN MELAMINE



N1NN N1AS N1BC N1CT N3NJ N3BD



FINITURE MELAMINICO  
MFC FINISHES  
FINITION EN MELAMINE

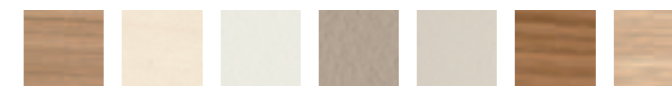

N1NN N1AS N1BC N1CT N2GT N2NO N2RO



N2WE N3RF N3RT N3CB N3NS N3LG



FINITURE MELAMINICO  
MFC FINISHES  
FINITION EN MELAMINE



N2GT N2NO N2RO



FINITURE MELAMINICO  
MFC FINISHES  
FINITION EN MELAMINE



N1BC N1NN N1AS N1CT N2NO N2WE N2RO



FINITURE LACCATO OPACO  
OPAQUE PAINTED FINISHES  
FINITION LAQUES OPAQUES



L\_TS L\_MC L\_CL L\_RC L\_AC L\_AB L\_SD L\_VA L\_BV L\_GS L\_CR \_\_\_\_ral